



PT2E-1744

Combustible Gas Detector Head

GD-D58・AC

GD-D58・DC

(TYPE GP)

(TYPE NC)

Operating Manual

RIKEN KEIKI Co., Ltd.

2-7-6 Azusawa, Itabashi-ku, Tokyo, 174-8744, Japan

Phone : +81-3-3966-1113

Fax : +81-3-3558-9110

E-mail : intdept@rikenkeiki.co.jp

Web site : <http://www.rikenkeiki.co.jp/english/>

Operating Precautions

This detector head is a gas detector that detects combustible gases in the air and triggers a gas alarm. The gas detector is a safety unit, not an analyzer or densitometer which performs quantitative/qualitative analysis/measurement for gases.

Please fully understand the following points before using it, so that it can be used properly.

1. This detector head may be interfered by gases and vapors other than the gas to be detected. Please note that the alarm may be triggered by interference. In addition, it may be fluctuated by environmental (temperature, humidity, etc.) changes in the installation site.
2. The alarm must be set within a range where the performance of the detector head can be ensured. In facilities compliant with the High Pressure Gas Safety Act, an alarm setting below our standard alarm setpoint may trigger a false alarm.
3. This is a safety unit, not a control unit.
The alarm contact output of the detector head must be used for an external alarm lamp/buzzer, while the alarm signal output must be used for an indicator or external recorder.
If these outputs are used to control other units, we shall not be responsible for any malfunctions.
4. The gas sensing part of the gas sensor installed in this detector head is made of metal porous sintered alloy permeated with an oxidation catalyst.
If silicon or sulfide compounds are accumulated on the surface of porous sintered alloy, the area of the gas sensing part becomes smaller, which may results in serious deterioration of its sensitivity.
For safety reasons, do not use the detector head under the presence of silicon or sulfide compounds even though their amount is very small.
5. For maintenance of the detector head, it must go through a regular maintenance, including replacement and adjustment of the regular replacement parts as specified in the operating manual. In addition, because this is a safety unit, it is recommended that a regular maintenance and a gas calibration are performed every six months in accordance with the regulations.

<Contents>

1.	Outline of the Product.....	4
1-1.	Preface	4
1-2.	Purpose of use	4
1-3.	Definition of DANGER, WARNING, CAUTION, and NOTE	4
1-4.	Method of confirmation for Standards and Explosion proof specification	5
2.	Important Notices on Safety	6
2-1.	Danger cases	6
2-2.	Warning cases	7
2-3.	Precautions	8
2-4.	Safety information	9
3.	Product Components.....	11
3-1.	Main unit and standard accessories	11
3-2.	Names and functions for each part.....	13
3-3.	Block diagram.....	16
4.	How to Use	18
4-1.	Before using the detector head	18
4-2.	Precautions for installation points	18
4-3.	Precautions for system designing.....	19
4-4.	How to install	21
4-5.	How to wire.....	22
4-6.	How to tube	29
5.	How to Operate	30
5-1.	Preparation for start-up.....	30
5-2.	Basic operating procedures.....	30
5-3.	How to start the detector head	31
5-4.	How to detect	32
5-5.	How to exit.....	32
6.	Alarm Activation.....	33
7.	Maintenance.....	34
7-1.	Maintenance intervals and items	34
7-2.	Parts replacement	36
8.	Storage, Relocation and Disposal	37
8-1.	Procedures to store the detector head or leave it for a long time	37
8-2.	Procedures to relocate the detector head or use it again	37
8-3.	Disposal of products	37
9.	Troubleshooting.....	38
10.	Product Specifications	40
10-1.	List of specifications	40
10-2.	Detection principle	46
11.	Definition of Terms.....	48

1

Outline of the Product

1-1. Preface

Thank you for choosing our fixed-type combustible gas detector head GD-D58 series. Please check that the model number of the product you purchased is included in the specifications on this manual.

This manual explains how to use the detector head and its specifications. It contains information required for using the detector head properly. Not only the first-time users but also the users who have already used the product must read and understand the operating manual to enhance the knowledge and experience before using the detector head.



Note that the detector head cannot be used by itself. Be sure to use it in combination with the dedicated indicator/alarm unit. Read also the operating manual of the indicator/alarm unit.

1-2. Purpose of use

- This detector head is a fixed type gas detector head which detects combustible gases.
- Use this detector head in combination with an indicator/alarm unit that indicates a gas concentration and triggers an alarm.
The detector head detects combustible gases and outputs voltages according to gas concentrations. The indicator/alarm unit both indicates a gas concentration and, if a preset concentration level is exceeded, triggers an alarm.
- The detector head is a safety unit, not an analyzer or densitometer which performs quantitative/qualitative analysis/measurement for gases. Please fully understand the features of the detector head before using it, so that it can be used properly.
- The detector head draws air with the built-in pump and detects abnormalities in the air caused by presence of gases or other reasons (leak) with the built-in gas sensor.
- The detector head has a built-in low flow rate detection function and can trigger a fault alarm when the flow rate inside the tubing drops below a fixed rate.
- The detector head has two types of power supply specifications.

GD-D58-AC	AC specification	100 - 110 VAC
GD-D58-DC	DC power specification	24 VDC

1-3. Definition of DANGER, WARNING, CAUTION, and NOTE

 DANGER	This message indicates that improper handling may cause death or serious damage on health or assets.
 WARNING	This message indicates that improper handling may cause serious damage on health or assets.
 CAUTION	This message indicates that improper handling may cause minor damage on health or assets.
NOTE	This message indicates advice on handling.

1-4. Method of confirmation for Standards and Explosion proof specification

This instrument has some specification depends on standard and explosion proof certificate. Please confirm the detector specification before using. Please refer Declaration of Conformity that is at the end of this manual if you have CE marking type. You can confirm instrument specification to see name plate as follows.

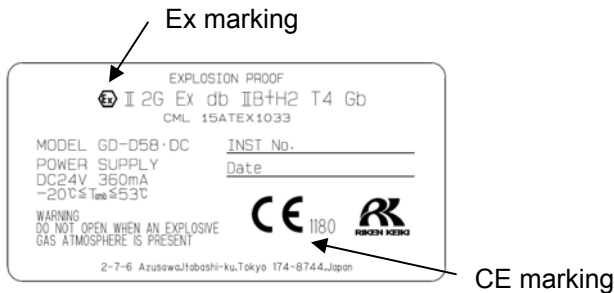

ATEX, CE marking type name plate
(DC power specification only)

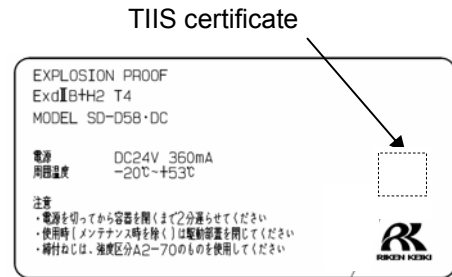

TIIS type name plate
(AC/DC power specification)

2

Important Notices on Safety

2-1. Danger cases



DANGER

<About explosion-proof>

- The window plate material is a polycarbonate resin. Do not use organic solvents and alkali types (liquid or vapor). It may cause the color and shape of the window plate to be changed.
- The flameproof joints are not intended to be repaired.
- Do not open the lid when applying current. The lid may be opened after five minutes or more after power off.
- Do not attempt to repair the detector head by the user.
- For the lid, use hexagon socket head bolts specified by RIKEN KEIKI.
- The drive lid must be closed during use (except during maintenance).

2-2. Warning cases



WARNING

Power supply

Before turning on the detector head, always check that the voltage is properly applied. Do not use an unstable power supply because it may cause malfunctions.

Need of grounding circuit

Do not cut the grounding circuit or disconnect the wire from the grounding terminal.

Defects in protective functions

Before starting the detector head, check the protective functions for defects. When seeming defects are found in the protective functions, such as protective grounding, do not start the detector head.

External connection

Before connecting the detector head to the external control circuit, securely connect it to a protective grounding circuit.

Zero adjustment in the atmosphere

When the zero adjustment is performed in the atmosphere, check the atmosphere for freshness before beginning the adjustment. If other gases exist, the adjustment cannot be performed properly, thus leading to dangers when the gas leaks.

Response to gas alarm

Issuance of a gas alarm indicates that there are extreme dangers. Take proper actions based on your judgment.

Do not use the detector head in the presence of silicone or sulfides.

The gas sensing part of the gas sensor and flow sensor is made of metal porous sintered alloy permeated with an oxidation catalyst. If silicon or sulfide compounds are accumulated on the surface of porous sintered alloy, the area of the gas sensing part becomes smaller, which may result in serious deterioration of its sensitivity.

2-3. Precautions



CAUTION

Do not use a transceiver or other equipment near the detector head.

Radio wave from a transceiver near the detector head or its cables may disturb operations. If a transceiver is used, it must be used in a place where it disturbs nothing.

To restart the detector head, wait for five seconds or more before doing it.

Restarting the detector head in less than five seconds may cause errors.

Do not disassemble/modify the detector head, or change the settings if not necessary.

Disassembling/modifying the detector head will invalidate the warranty of the performance. Changing the settings without understanding the specifications may cause alarm malfunctions. Please use the detector head properly in accordance with the operating manual.

Avoid applying organic solvents and others to the window plate for a long time.

The window plate material is a polycarbonate resin. When organic solvents (liquid or highly-concentrated vapor) and others are applied to the plate for a long time, its color and shape may be changed.

Never fail to perform a regular maintenance.

Since this is a safety unit, a regular maintenance must be performed to ensure safety. Continuing to use the detector head without performing a maintenance will deteriorate the sensitivity of the sensor, thus resulting in inaccurate gas detection.

Do not use the detector head under an inert gas atmosphere.

The flow rate cannot be measured correctly under an inert gas atmosphere such as He.

2-4. Safety Information

Necessary information for explosion proof construction of Model GD-D58-AC/GD-D58-DC.

This product is a diffusion type gas detector which is basically installing fixed place.

<ATEX Specifications>

Technical Data

(Protection Method)	Flameproof enclosure "d"
(Group)	II
(Category)	2G
(Type of Protection and Marking code)	Ex db II B+H2 T4
(Equipment Protection Level)	Gb
(Ambient Temperature)	-20°C to +53°C
(Electrical Data)	
Supply voltage :	24 Vdc(Typ.)
Electrical rating :	DC3.0V 430mA or DC5.0V 200mA
(Applicable Standard)	EN 60079-0 : 2012, EN 60079-1: 2014

Installation

【GD-D58 · DC】

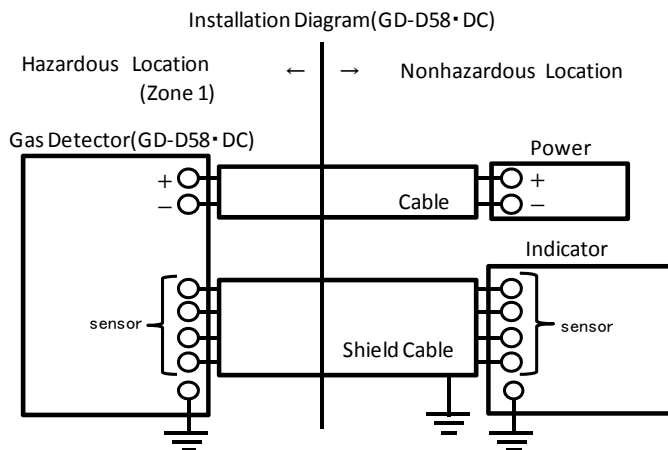

<TIIS Specifications>

Technical Data

(Protection Method)	Flameproof enclosure
(Explosion-proof class)	Ex d II B+H2 T4
(Ambient Temperature)	Type AC: -20°C to 50°C Type DC: -20°C to 53°C
(Electrical Data)	
Supply voltage :	Type AC: AC100~110V 50/60Hz 120mA Type DC: DC24V 360mA
Electrical rating :	DC3.0V 430mA or DC5.0V 200mA
(Applicable Standard)	JNIOSH-TR-NO. 43(2008)

Installation

【GD-D58・AC】

【GD-D58・DC】

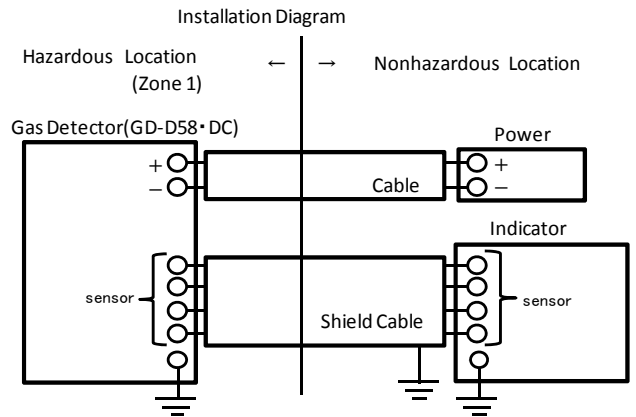
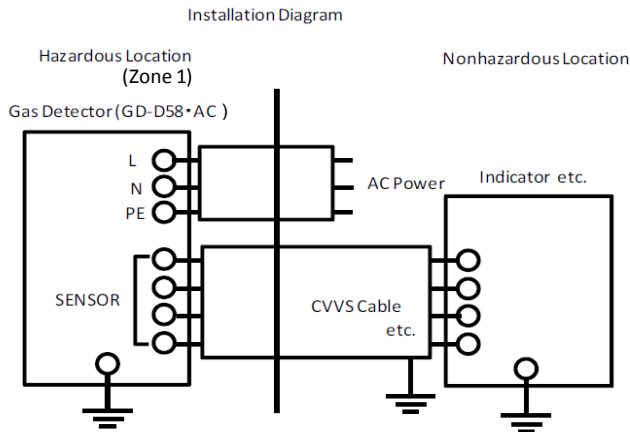

3

Product Components

3-1. Main unit and standard accessories

<Main Unit> (including cable glands)

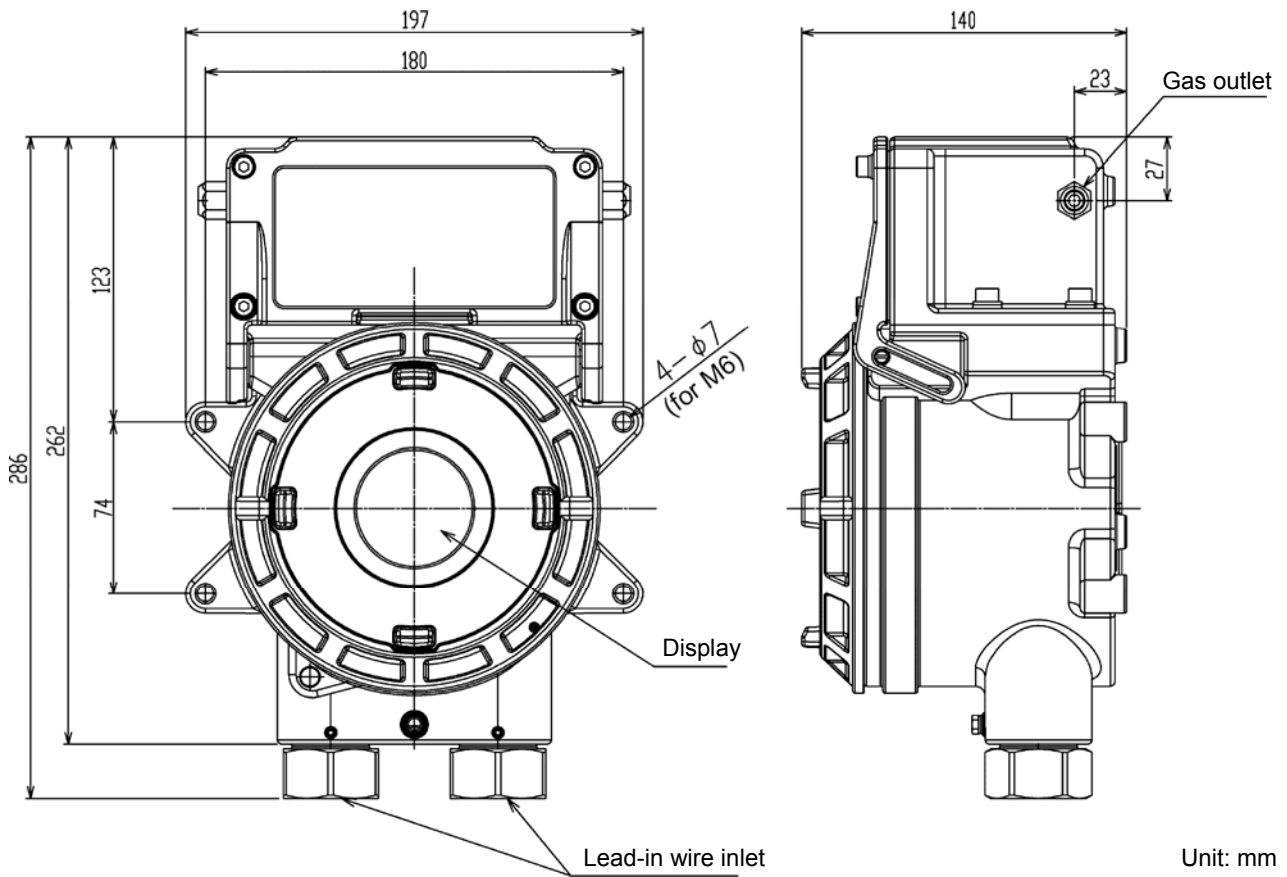

Unit: mm

<Standard Accessories>

- Operating manual
- Dedicated handling lever 1 lever
- Dedicated control key The control key quantity depends on the number of detector heads to be delivered.

1 - 10 units	1 key
11 - 20 units	2 keys
21 - 50 units	3 keys
Over 51 units	4 keys

- Hex key wrench Same number of wrenches as with the test certificates will be provided.
- Dust removal filter with flow monitor 1 filter



CAUTION

- Use the supplied dedicated control key to operate the detector head. If products other than these accessories are used, key operations cannot be accepted properly.
- The control key is made of an extremely strong magnet. Keep it away from a credit card, ID card, or other magnetic product because stored data may be destroyed.

NOTE

The dedicated control key is for maintenance. It is not used for detection mode. Keep it handy for use.

3-2. Names and functions for each part

<Display>

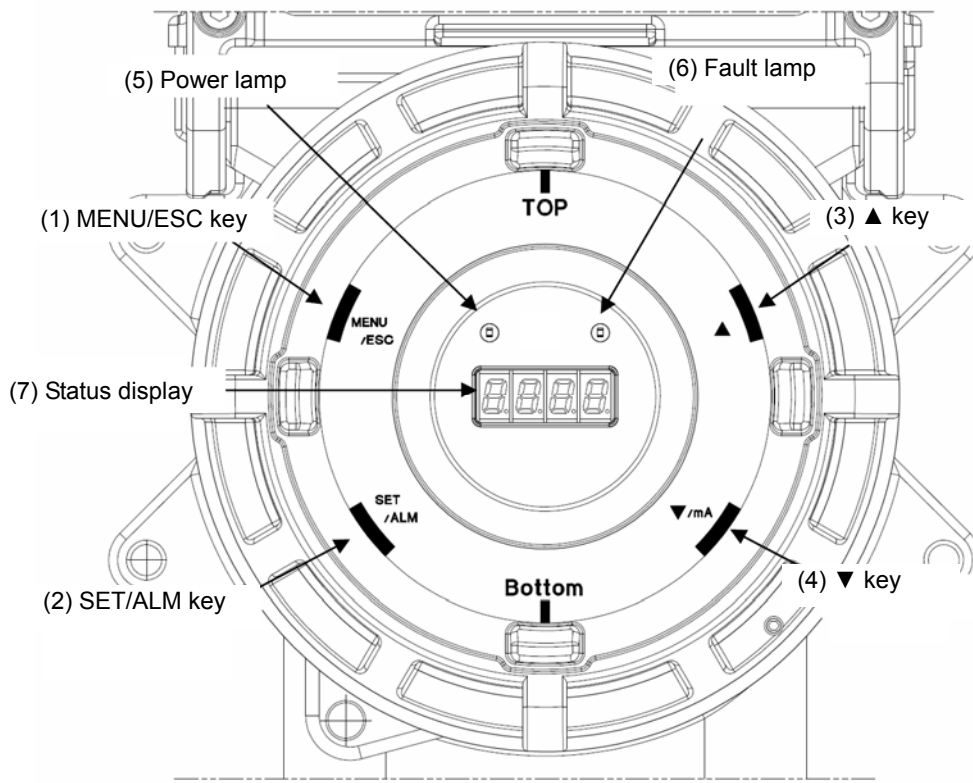

(1)	MENU/ESC key *	Used to enter the maintenance mode. It is also used to cancel in a specific mode.
(2)	SET/ALM key *	It is used for value confirmation and so on in a specific mode.
(3)	▲ key *	Used to switch menus or change a value (UP).
(4)	▼ key *	Used to switch menus or change a value (DOWN).
(5)	Power lamp	Power lamp. Detection mode: It lights up in green. Maintenance mode: It blinks in green.
(6)	Fault lamp	Fault lamp. It lights up in yellow when an abnormality is detected in the detector head.
(7)	Status display	Displays the operating status.

* This is not typically used by the user.

NOTE

The nameplate on the front side of the detector head shows the precautions to be taken for explosion-proof performances. Read these precautions as well as "2. Important Notices on Safety."

<Inside of the main unit> (Electric circuit section)

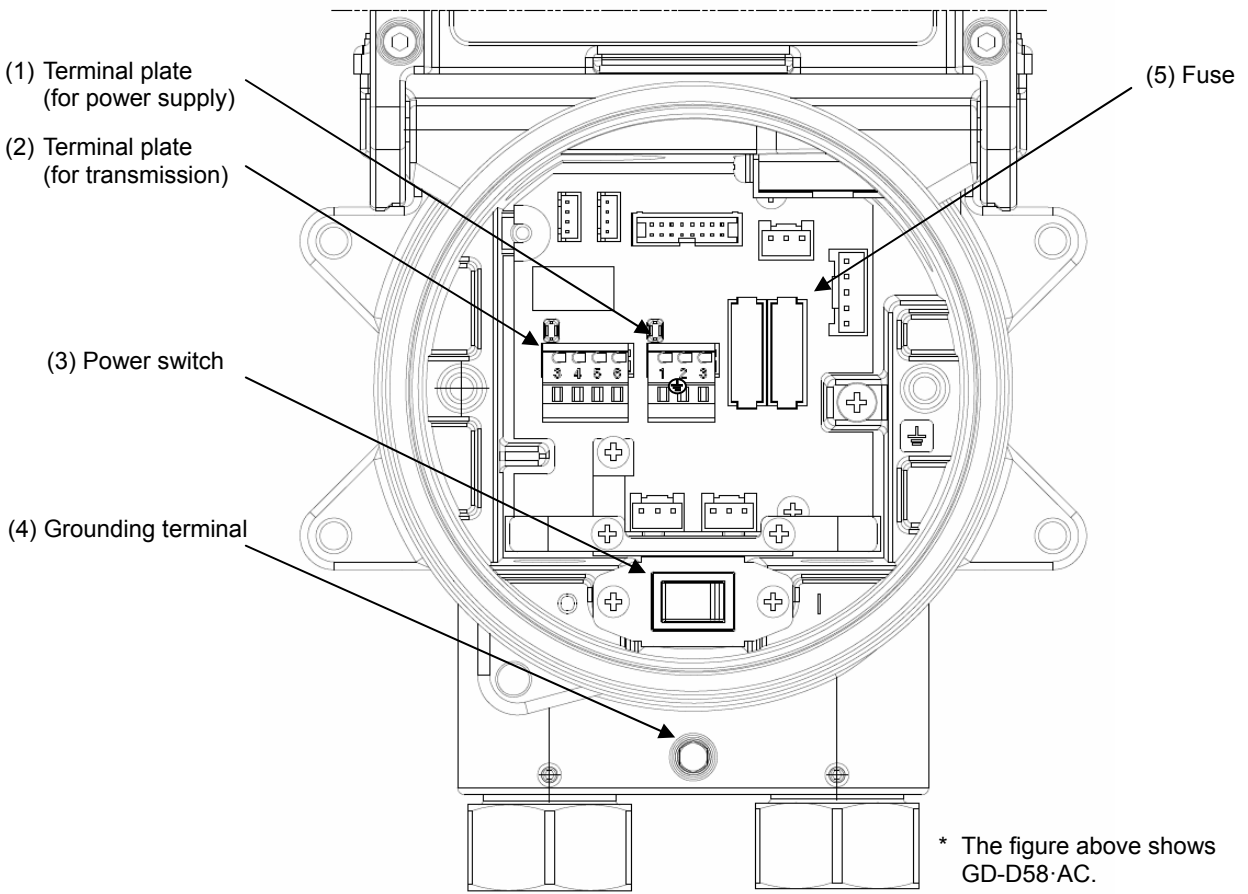

(1)	Terminal plate (for power supply)	Power input terminal plate (GD-D58·AC: 3-pole, GD-D58·DC: 2-pole).
(2)	Terminal plate (for transmission)	Terminal plate for transmission.
(3)	Power switch	Power switch of the detector head (GD-D58·AC only).
(4)	Grounding terminal	Terminal for grounding (M4 x 6).
(5)	Fuse	Main power fuse (GD-D58·AC only).

NOTE

- Open the electric circuit lid.
Remove the electric circuit lid and display unit to find behind them the electric circuit section shown in the figure above.

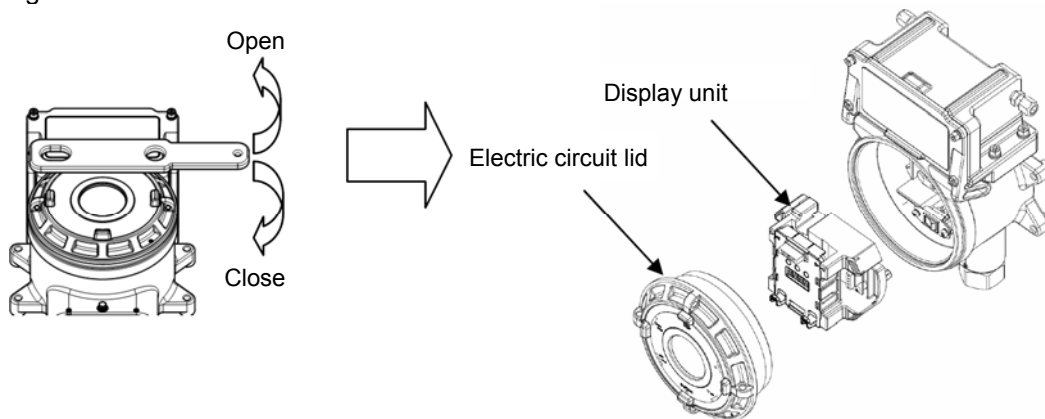

- Power input terminal plates are GD-D58·AC: 3-pole and GD-D58·DC: 2-pole.
- After use, closely tighten the lid until the thread is no longer seen and the "TOP" marking faces upward.

<Inside of the main unit> (Drive section)

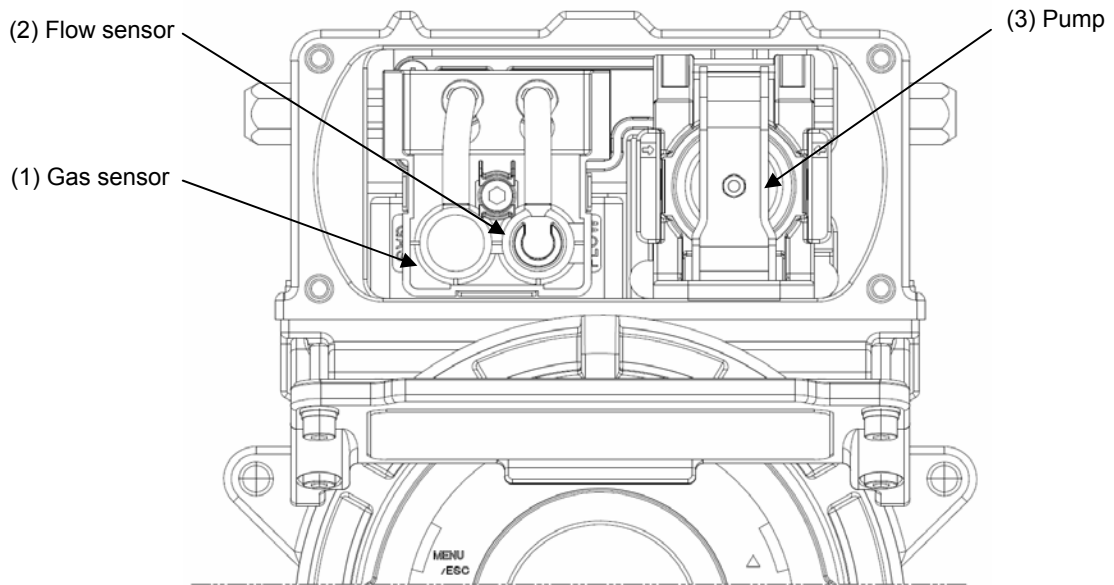

(1)	Gas sensor	Gas detection sensor.
(2)	Flow sensor	Sensor for detection of low flow rate.
(3)	Pump	Sample draw pump.

NOTE

Loosen the drive lid and the hexagon socket head bolts on the four corners.

Remove the drive lid to find the drive section shown in the figure above.

The bolt with the hexagon socket must use the stainless steel material of property class "A2-70".

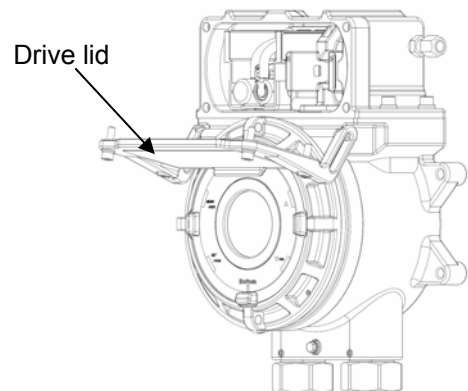

3-3. Block diagram

<Electric Diagram>

GD-D58-AC

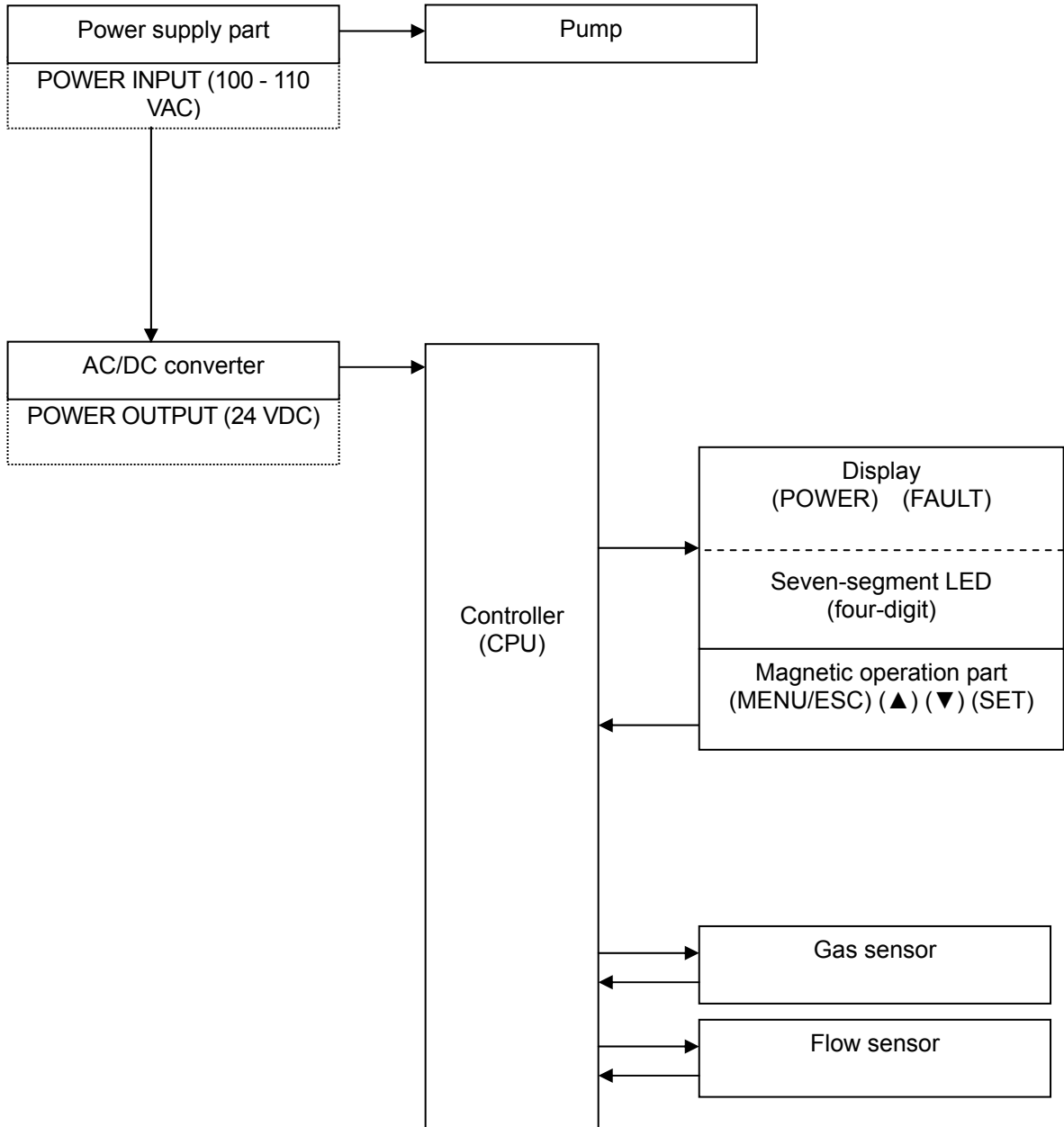

<Electric Diagram>

GD-D58·DC

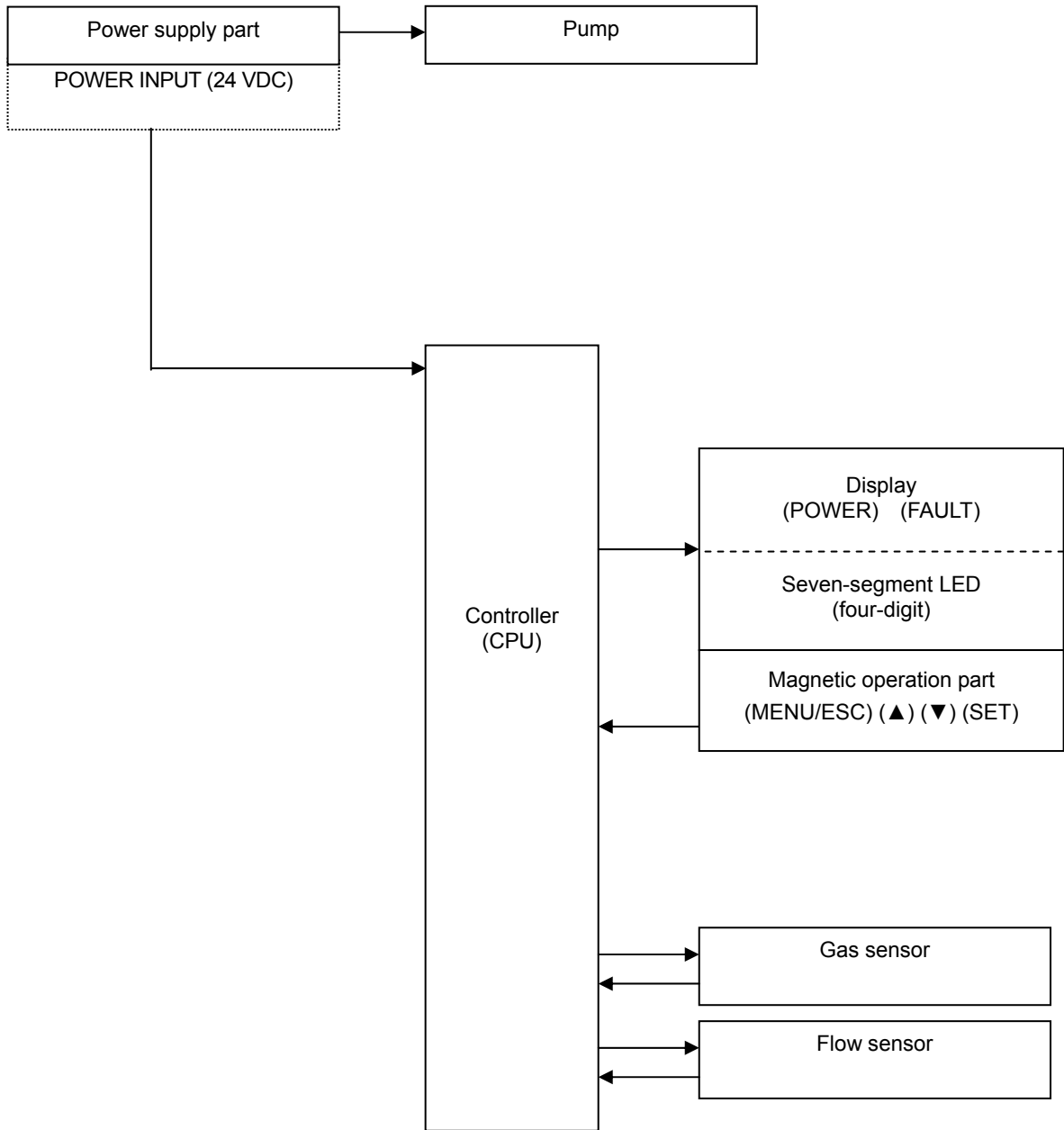

4

How to Use

4-1. Before using the detector head

Not only the first-time users but also the users who have already used the product must follow the operating precautions.

Ignoring the precautions may damage the detector head, resulting in inaccurate gas detection.

4-2. Precautions for installation points



CAUTION

- This detector head is a precision device. Because the detector head may not provide the specified performance in some places (environments), check the environment in the installation point, and then take appropriate actions if necessary.
- Because the detector head plays an important role for safety and disaster prevention, as many units of the detector head as needed must be installed in appropriate points. Because points where gases leak and remain easily are different depending on the types of gases and the working areas, please decide carefully on installation points and the number of units to be installed.

Do not install the detector head in a place with vibrations or shocks.

The detector head consists of sensitive electronic parts. The detector head must be installed in a stable place without vibrations or shocks and it cannot drop.

Do not install the detector head in a place exposed to water, oil or chemicals.

When selecting installation points, avoid a place where the detector head is exposed to water, oil or chemicals.

Do not install the detector head in a place where the range of operating temperatures is exceeded.

The detector head must be installed in a stable place where the operating temperature is maintained and do not change suddenly.

<ATEX Specifications> GD-D58 · DC : -20°C~+53°C

<TIIS Specifications> GD-D58 · AC : -20°C~+50°C / GD-D58 · DC : -20°C~+53°C

Do not install the detector head in a place exposed to direct sunlight or sudden changes in the temperature.

When selecting installation points, avoid a place where it is exposed to direct sunlight or radiant heat (infrared rays emitted from a high-temperature object), and where the temperature changes suddenly. Condensation may be formed inside the detector head, or the detector head cannot adjust to sudden changes in the temperature.

Keep the detector head (and its cables) away from noise source devices.

When selecting installation points, avoid a place where high-frequency/high-voltage devices exist.

Do not install the detector head in a place where maintenance of the detector head cannot be performed or where handling the detector head involves dangers.

Regular maintenance of the detector head must be performed.

Do not install the detector head in a place where the machinery must be stopped when maintenance is performed in its inside, where parts of the machinery must be removed to perform maintenance, or where the detector head cannot be removed because tubes or racks prevent access to it. Do not install the detector head in a place where maintenance involves dangers, for example, near a high-voltage cable.

Do not install the detector head in machinery which is not properly grounded.

Before installing the detector head in machinery, the machinery must be grounded properly.

Do not install the detector head in a place where other gases exist around it.

The detector head must not be installed in a place where other gases exist around it.

4-3. Precautions for system designing



CAUTION

An unstable power supply and noise may cause malfunctions or false alarms.

The descriptions in this section must be reflected on the designing of a system using the detector head.

Using a stable power supply

The external output and alarm contact of the detector head may be activated when the power is turned on, when momentary blackout occurs, or while the system is being stabilized. In such cases, use a UPS (uninterrupted power supply), or take appropriate actions on the receiving side of output signals.

The detector head must be provided with the following power supply.

Power supply voltage	GD-D58·AC: 100 - 110 VAC \pm 10%, 50/60Hz: Terminal voltage of the detector head GD-D58·DC: 24 VDC \pm 10%: Terminal voltage of the detector head	
Allowed time of momentary blackout	GD-D58·AC: Less than approx. 200 msec (To recover from the momentary blackout for 200 milliseconds or more, restart the detector head.) GD-D58·DC: Less than approx. 10 msec (To recover from the momentary blackout for 10 milliseconds or more, restart the detector head.)	<u>Example of actions</u> To ensure continuous operation and activation, install an UPS outside the detector head.
Others	Do not use it with a power supply of large power load or high-frequency noise.	<u>Example of actions</u> Use a line filter to avoid the noise source if necessary.

Introducing protective measures against lightning

If cables are installed outside the factory/plant, or if internal cables are installed in the same duct as the cables coming from outside the factory/plant, "lightning" will cause problems. Because lightning acts as a large emission source while cables act as a receiving antenna, devices connected to the cables may be damaged.

Lightning cannot be prevented. Cables installed in a metal conduit or under the ground cannot be completely protected from inductive lightning surge caused by lightning. Although complete elimination of disasters caused by lightning is impossible, the following protective measures can be taken.

Protection against lightning	<p><u>Take appropriate measures in accordance with the importance of the facilities and the environment.</u></p> <ul style="list-style-type: none"> • Provide protection by a lightning arrester (cable arrester). (Although inductive lightning surge can be transmitted through the cable, it is prevented by installing a lightning arrester before the field devices and central processing equipment. For information on how to use a lightning arrester, please contact the manufacturer.)
Grounding	<p>In addition to lightning, there are more sources of surge noise. To protect units from these noise sources, the units must be grounded.</p>

* The lightning arrester has a circuit to remove a surge voltage which damages field devices, so that signals may be attenuated. Before installing a lightning arrester, verify that it works properly.

4-4. How to install

<Installation Dimensions and Maintenance Space>

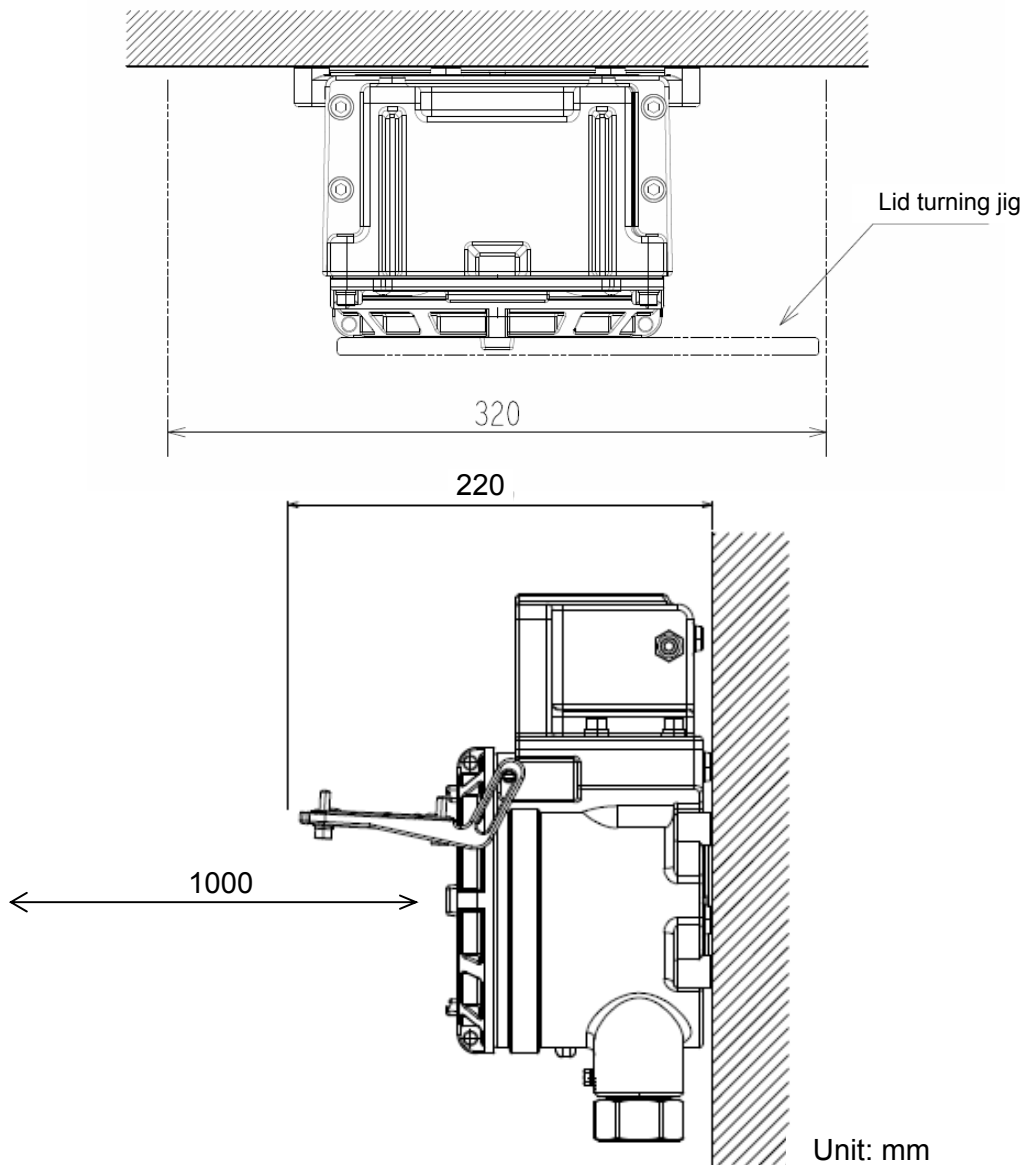

The following installation requirements must be met to install the detector head.

- Attach the detector head on the wall or elsewhere, using four M6 screws.



CAUTION

Do not install the detector head in a place where maintenance of the detector head cannot be performed or where handling the detector head involves dangers.

Regular maintenance of the detector head must be performed.

Do not install the detector head in a place where the machinery must be stopped when maintenance is performed in its inside, where parts of the machinery must be removed to perform maintenance, or where the detector head cannot be removed because tubes or racks prevent access to it. Do not install the detector head in a place where maintenance involves dangers, for example, near a high-voltage cable.

4-5. How to wire



WARNING

- When installing the electric circuit lid, do not let any foreign substance such as metal get into the terminal box.
This can cause a failure of the device or loss of explosion-proof performance.
- The lead-in wire to the detector head must be installed in a way not to damage the explosion-proof performance of the detector head.



CAUTION

- Be careful not to damage the internal electronic circuit when wiring. In addition, be careful not to apply stresses on the detector head when (overweight) cables are installed.
- The power cables and signal cables must not be installed together with the motor power cables, etc. When these cables must be installed together for unavoidable reasons, put the power cables and signal cables in a metal conduit. The conduit must be connected to a grounding circuit.
- When stranded wires are used, prevent wires from contacting each other.
- Use the dedicated handling lever to wire.
- Use appropriate cables to wire.

<Recommended Cables>

Power cable	CVV, etc. (1.25 sq or 2 sq) - 2-core ^{*1} or 3-core ^{*1*2}
Transmission cable	CVV, etc. (1.25 sq or 2 sq) - 4-core ^{*1} or 6-core ^{*3}

*1 When power cables and transmission cables are laid out separately.

*2 When internal grounding terminal poles are used.

*3 When the same cable is used for power and transmission. * The wiring diameter is 1.25sq.

<Parts. Length table of outside conductor lead-in>

<ATEX Specifications>

Cable outer diameter (mm)	Rubber seal inner diameter (mm)	Washer inner diameter (mm)	Eccentric washer inner diameter (mm)
φ9.0 -φ9.6	φ10	φ10	φ9.8
φ9.6 -φ11.0	φ11	φ14	φ11.8
φ11.0 -φ12.0	φ12	φ14	φ12.8
φ12.0 -φ12.5	φ12.5	φ14	φ12.8
φ12.5 -φ13.5	φ13.5	φ14	φ13.8
φ13.5 -φ14.5	φ14.5	φ17	φ14.8
φ14.5 -φ15.5	φ15.5	φ17	φ15.8
φ15.5 -φ16.0	φ16.5	φ17	φ16.2
No cable		- (Plug)	

<TIIS Specifications>

Cable outer diameter (mm)	Rubber seal inner diameter (mm)	Washer inner diameter (mm)	Eccentric washer inner diameter (mm)
φ9.0 -φ9.6	φ10	φ14	φ9.8
φ9.6 -φ10.5	φ11	φ14	φ9.8
φ10.5 -φ11.0	φ11	φ14	φ11.8
φ11.0 -φ12.0	φ12	φ14	φ12.8
φ12.0 -φ12.5	φ12.5	φ14	φ12.8
φ12.5 -φ13.0	φ13.5	φ14	φ13.8
φ16.0	φ16.5	φ17	φ16.2
No cable	- (Plug)		

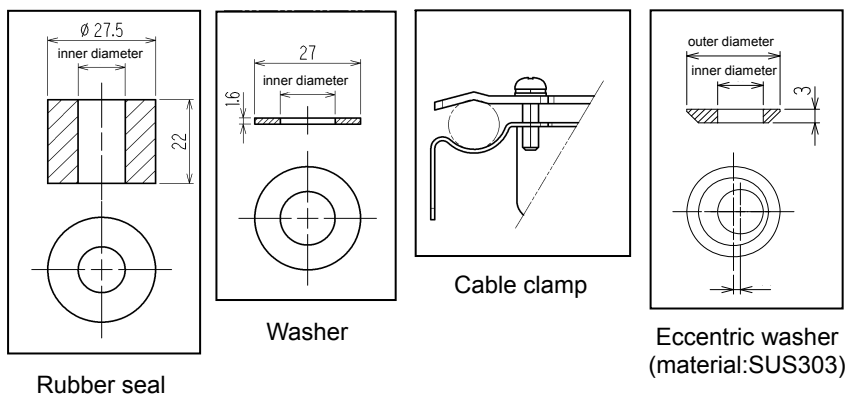

NOTE

- The following table shows an example of the outer diameters of the cables. Use them for reference. The outer diameters must be checked because they somewhat vary between manufacturers.

Number of core	CVV 1.25sq	CVV 2sq	CVVS 1.25sq	CVVS 2sq
2	φ 9.2	φ 10.5	φ 9.6	φ 10.5
3	φ 9.7	φ 11.0	φ 10.5	φ 11.0
4	φ 10.5	φ 11.5	φ 11.0	φ 12.0
5	φ 11.5	φ 12.5	φ 12.0	φ 13.0
6	φ 12.5	φ 13.5	φ 13.0	φ 14.0

<Figure of Terminal Plate>

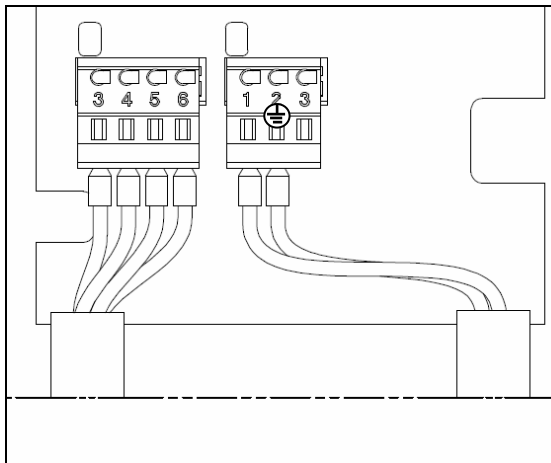

* The figure above shows GD-D58·AC.

GD-D58·AC

TN2				TN1		
3	4	5	6	1	2	
3	4	5	6	AC (L)	AC (N)	FG
Detector head signal				Pump power supply 100 - 110 VAC input		

GD-D58·DC

TN2				TN1	
3	4	5	6	1	2
3	4	5	6	5	-
Detector head signal				Pump power supply 24 VDC input	

NOTE

- Open the electric circuit lid.
Remove the electric circuit lid and display unit to find behind them the terminal plate shown in the figure above.

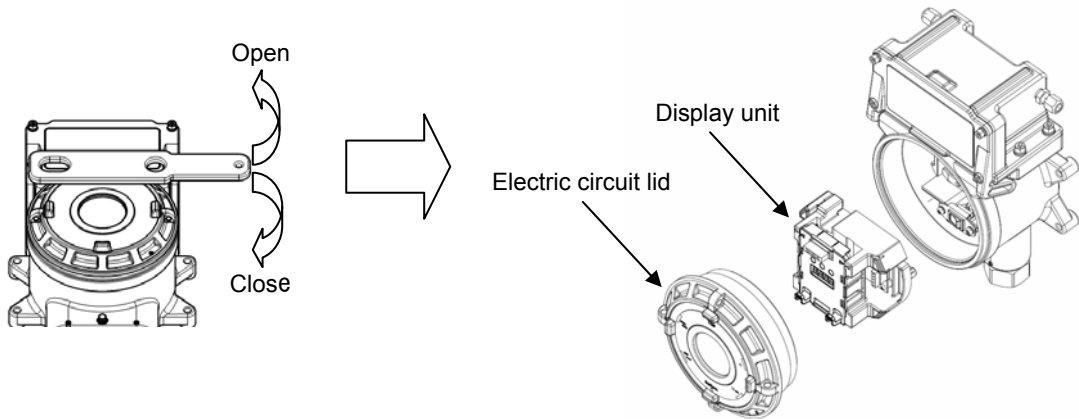

- Power input terminal plates are GD-D58·AC: 3-pole and GD-D58·DC: 2-pole.
- After use, closely tighten the lid until the thread is no longer seen and the "TOP" marking faces upward.

<Specifications of Terminal Plate>

Specifications of terminal plate

- Rated voltage: 250 VAC
- Rated current: 12 A
However, it depends on the cables to be used.

Connection conditions

- Cables: 0.25 - 2.5 mm²
- Bare wire length: 8 - 9 mm
- Connecting tool: Dedicated handling lever (accessory) or driver (edge 3.5 x 0.5 mm)



CAUTION

The specified bare wire length must be observed when the wire insulation is peeled off.

- Improper clamping of the wire due to a shorter bare wire length may cause defective electric conduction or heating.
- Catching the wire insulation due to a shorter bare wire length may cause defective electric conduction or heating.
- Exposing the wire due to a longer bare wire length may cause defective insulation or a short circuit.
- Be careful not to break up the wire. If the wire is broken up when inserted to the terminal, this may cause defective insulation or heating.

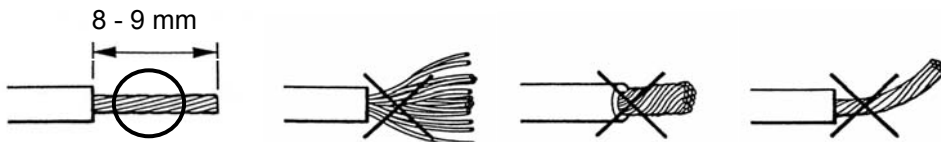

Compatible bar terminal

For a bar terminal, the following items are available.

- Bar terminal (ferrule): Model 216 Series (manufactured by WAGO)
- Crimping tool: Model VarioCrimp 4 (206-204) (manufactured by WAGO)



CAUTION

A bar terminal of the specified model must be used. Using other bar terminals invalidates the warranty of the performance.

<How to Connect to Terminal Plate>

When cables are connected to the connectors, use the dedicated lever or a flathead screwdriver to do it as shown below.



CAUTION

- The appropriate tools must be used.
- In principle, one wire can be connected to one wiring hole.
- When the wire is inserted into the driver slot by mistake, it does not contact the conductive part. This may cause defective electric conduction or heating. When the wire is inserted under the spring by mistake, it does not contact the conductive part. This may cause defective electric conduction or heating.

NOTE

<How to Use the Dedicated Handling Lever>

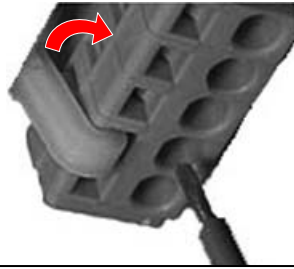

Push the lever with your finger to lower the spring in its inside.

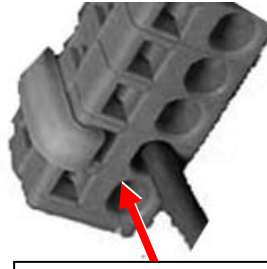



While holding down the lever, insert the wire into the (round) wiring hole until it reaches the deepest point. Once the lever is released, the wire is secured.

To check whether the wire is connected securely, pull the wire gently. (Do not pull the wire strongly.)

<Attaching External Cable>

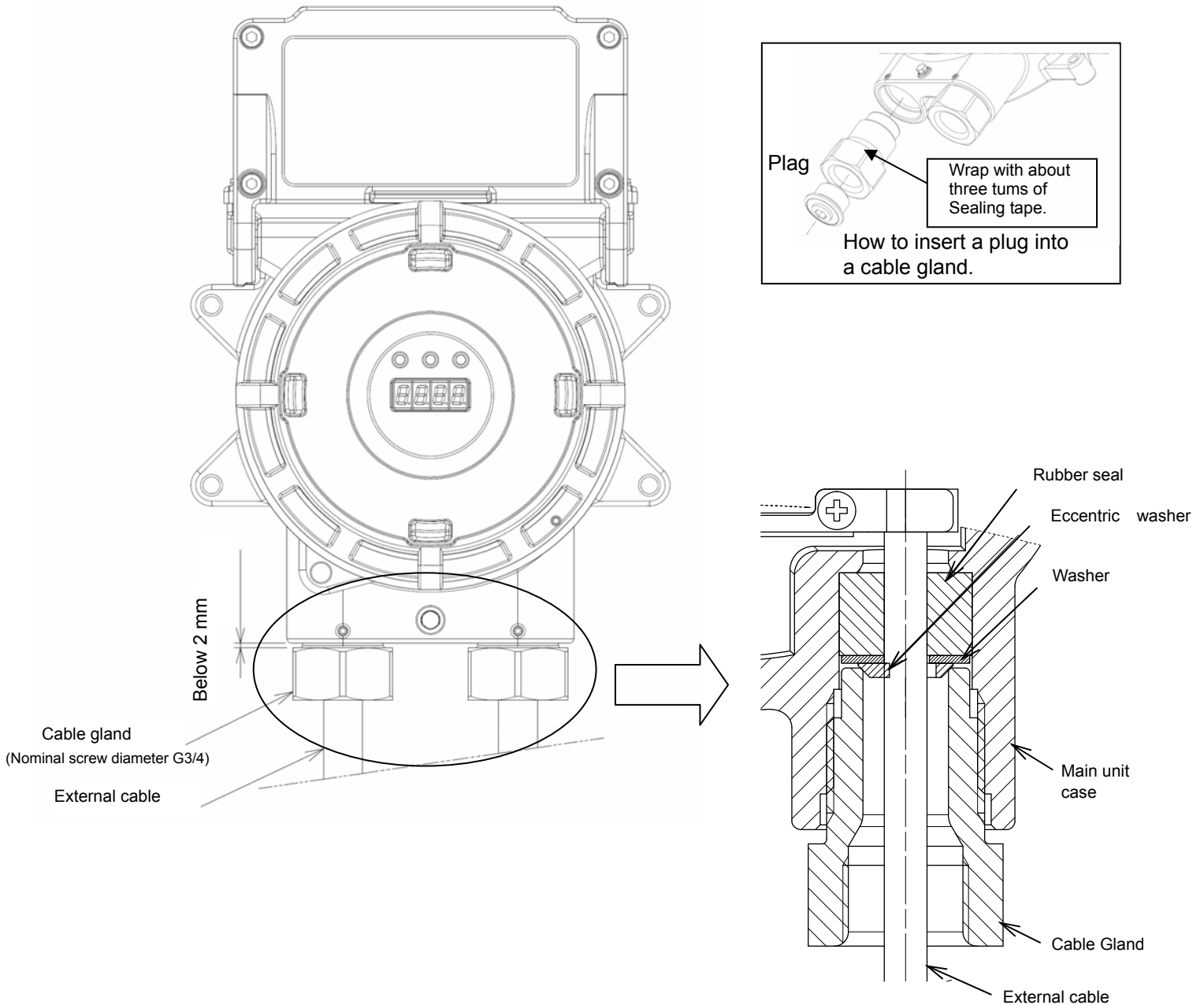
As shown on the figure below, attach the parts in the following order: cable gland, eccentric washer, washer, and rubber seal to the cable, then connect the cable into the main unit, then screw the cable gland to tighten the rubber seal.





CAUTION

- Tighten a cable gland with a tool until a clearance between the cable gland and a main unit case is below 2.0 mm.
- If it is difficult to tighten the cable gland, grease its screw part and then tighten it with the tool.

<Grounding>

Connect the detector head  to your grounding terminal with the external grounding terminal.



WARNING

- Before turning on the detector head, do not forget to connect it to a grounding terminal.
- For stable operation of the detector head and safety, it must be connected to a grounding terminal. Do not connect the grounding wire to a gas pipe.
- The grounding must be made as D type grounding (below 100 Ω of grounding resistance).
- For the grounding wire, use cable lugs to safely connect it to a grounding terminal without looseness or twist.
- To connect the grounding wire to the internal grounding terminal of the unit, use a crimped terminal to which a wire with a cross-section area of 4 mm² or more can be attached.

<Wiring Example>

Connecting to the indicator/alarm unit

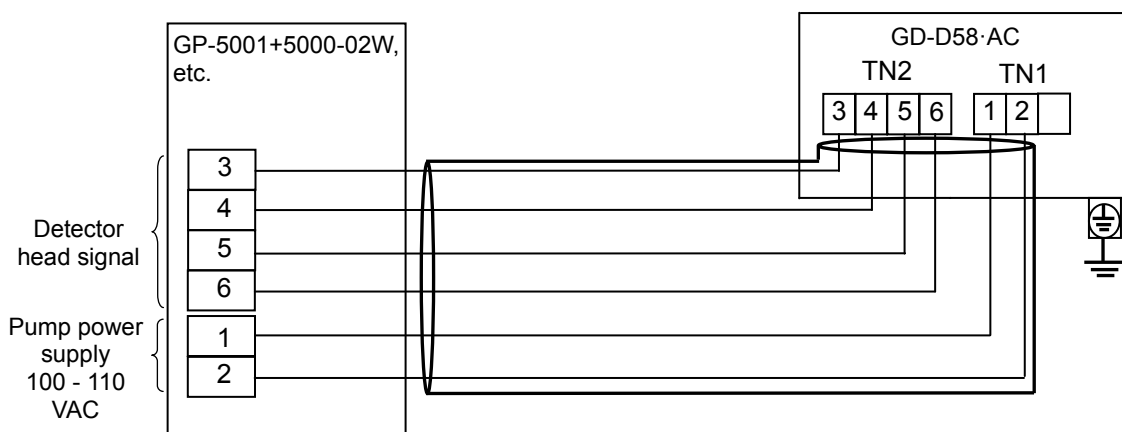
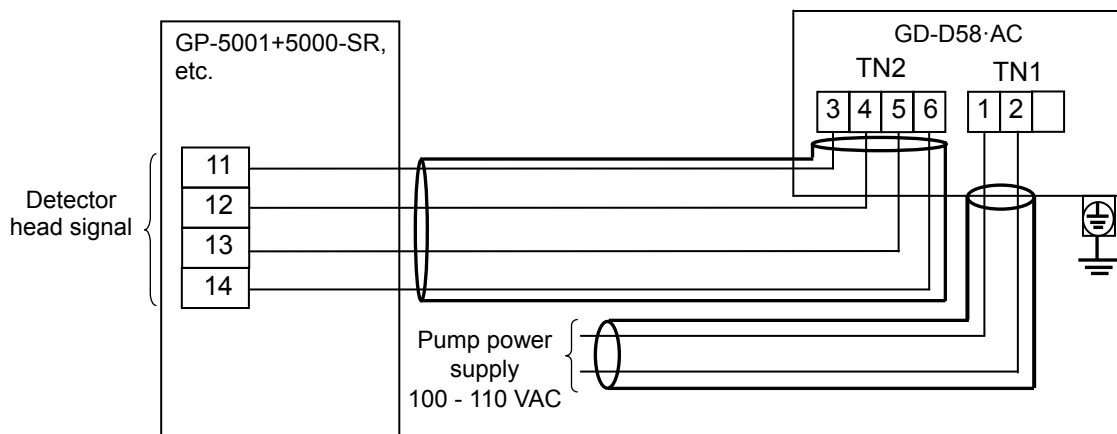

* The terminal plate number depends on the indicator/alarm unit. For details, see the operating manual of the indicator/alarm unit.

4-6. How to tube

The detector head has an Rc1/8 thread inside of the sampling inlet/outlet (GAS IN, GAS OUT), to which BS unions are attached as standard. Because their material varies depending on the gas to be detected, please specify the material.

The compatible tube is a copper tube of $\Phi 8$ (OD) - $\Phi 6$ (ID). The tube must be installed with the supplied sleeves attached to prevent a leak.

When the tube is cut, its cut point may have a smaller inner diameter. Use a file etc. to expand the inner diameter of the cut point. To remove cut-dust remaining inside of the tube, blow compressed air etc. into the tube before connecting it to the detector head.

Some sample gases have highly adsorptive or corrosive properties. Select the tube material taking into account these precautions.



WARNING

- The detector head is designed to draw gases under the atmospheric pressure. If excessive pressure is applied to the sampling inlet and outlet (GAS IN, GAS OUT) of the detector head, detected gases may be leaked from its inside, thus leading to dangers. Avoid applying excessive pressure to the detector head while in use.
- Gases must be exhausted from the gas exhausting outlet (GAS OUT) to which an exhaust tube is connected, to a point regarded as a safe place.
- Do not use the detector head in the presence of silicone or sulfides. The gas sensing part of the gas sensor and flow sensor is made of metal porous sintered alloy permeated with an oxidation catalyst. If silicon or sulfide compounds are accumulated on the surface of porous sintered alloy, the area of the gas sensing part becomes smaller, which may result in serious deterioration of its sensitivity.
- Do not use the detector head under an inert gas atmosphere. The gas cannot be detected correctly under an inert gas atmosphere such as He.



CAUTION

- The longer the tube of the GAS IN is, the longer it takes for a sample gas to reach the detector head. The length of the GAS IN tube must be minimized, since some gases have a highly adsorptive property which results in slower responses, and possibly a lower reading than the actual value.
- When the humidity in the sampling point is high, condensation may be formed inside of the tube. (Make sure to avoid condensation when using a gas such as a strong acid gas, which is dissolved into water and corrodes contacted materials, because it may result in undetectable condition and furthermore may corrode internal parts.) Also avoid an excessive U-shaped or V-shaped tube.
- Determine the inlet for the sample gas, considering the air flow of the sample gas line and the gas generating process.
- To remove dust, never fail to attach the supplied dust filter in the middle of the tube.
- It is needed to decide the length and material of the tube. Please contact RIKEN KEIKI for more information.
- Do not use the detector head under an inert gas atmosphere. The flow rate cannot be detected correctly under an inert gas atmosphere such as He.
- During tubing work, do not bend tubes at a right angle but install them as straight as possible. Applying too much load on a tube may put too much strain on the pump of the detector head and shorten the pump life. If bending of a tube is unavoidable, bend it with an appropriate radius to minimize strain.

5

How to Operate

5-1. Preparation for start-up

Before supplying power, read and understand the following precautions. Ignoring these precautions may cause an electric shock or damage the detector head.

- Check that the detector head is installed properly.
- Check that the detector head is connected to a grounding circuit.
- Check that the wiring is connected to external device properly.
- Check that the tubes are installed properly.
- Check that the power supply voltage is compliant with the power supply specification and does not exceed the rating.

5-2. Basic operating procedures

Normally, the detection mode is activated after the power is turned on.

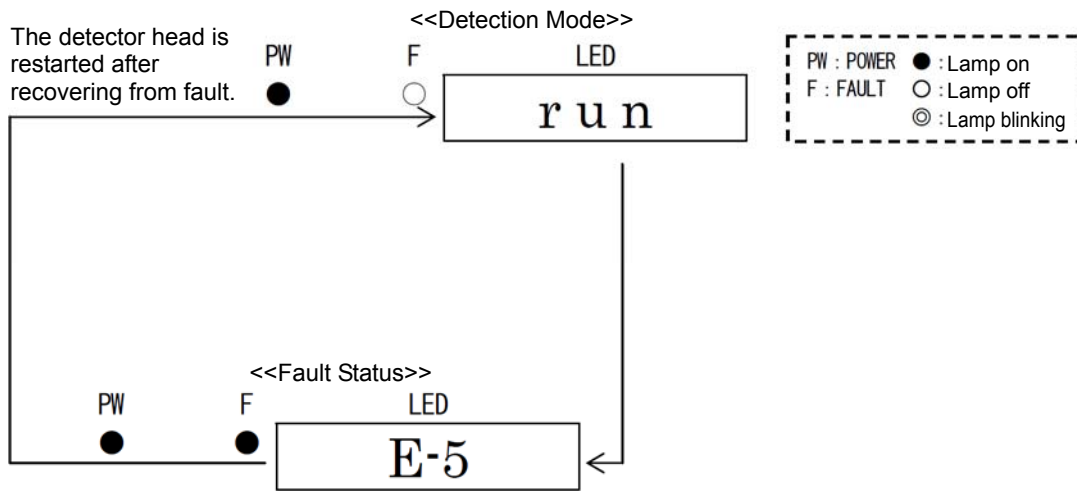

* Example of display: E-5 Low Flow Rate Alarm

5-3. How to start the detector head

- Before supplying power to the detector head, check that the preparation for start-up is completed.
 - Open the electric circuit lid.*
 - Turn ON the power switch.*
 - Close the electric circuit lid.*
 - Supply power to the detector head.
 - After the detector head completes the start-up, it enters the detection mode swiftly.
- * Only GD-D58·AC has a power switch. Since GD-D58·DC does not have any power switch, there is no need to open or close the electric circuit lid.



DANGER

Do not turn off the detector head during the initial clear. The detector head is reading the internal memory during the initial clear.

NOTE

- <<Start-up Operation Procedures>> (approximately 25 seconds for system check of the detector head and alarm deactivation)
Power on -> Initial clear (approximately 25 seconds) -> Detection mode
- The gas detection is not yet started just after the detector head is started up. Turn ON the power switch of the indicator/alarm unit according to "5-4. How to detect."

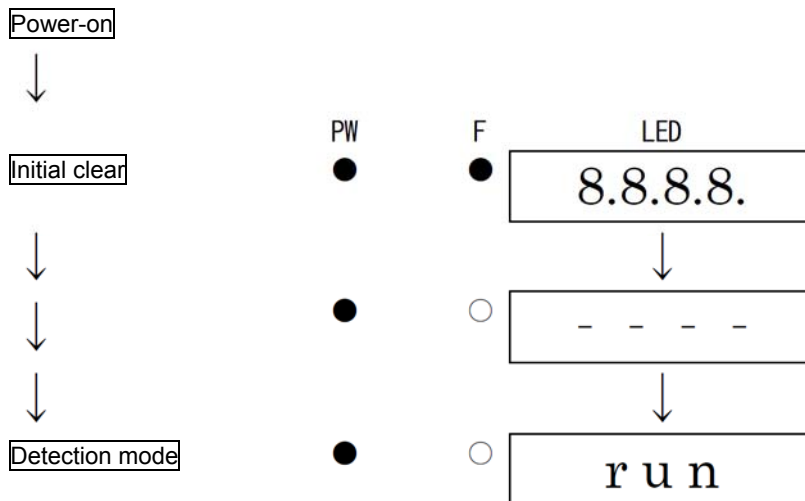

5-4. How to detect

- Turn ON the power switch of the indicator/alarm unit. The gas detection is started after the initial clear* of the indicator/alarm unit.
- Check that the operation is normal in accordance with the operating manual of the indicator/alarm unit. Make sure that the flow rate of the detector head is appropriate.
- * The initial operation just after power-on depends on the indicator/alarm unit. For details, see the operating manual of the indicator/alarm unit.



CAUTION

- If a new sensor is installed or the sensor is replaced even after the start-up, the sensor must be warmed up for a specified period which is determined depending on the type of the sensor.
- After the warm-up is completed, perform a gas calibration.

5-5. How to exit

- Turn OFF the power switch of the indicator/alarm unit.
- Turn off the power supply to the detector head.
- Open the electric circuit lid.*
- Turn OFF the power switch of the detector head.
- Close the electric circuit lid.*
- * Only GD-D58·AC has a power switch. Since GD-D58·DC does not have any power switch, there is no need to open or close the electric circuit lid.



WARNING

- When the detector head is turned off, an alarm may be triggered on the upper (central) system.
- Before turning off the detector head, INHIBIT (point skip) on the upper (central) system must be activated. Decide whether the power can be turned off by checking the operation of the devices connected to the external output or external contact output terminal of the detector head.

6

Alarm Activation

A fault alarm is triggered when the detector head detects abnormalities. After a fault alarm is triggered, the fault lamp (yellow) lights up and an error message is displayed on the LED. Determine the causes and take appropriate actions.

After the detector head is successfully returned from the fault, it restarts with the process normally performed right after it is turned on (initial clear).

If the detector head has problems and is repeatedly malfunctioning, contact RIKEN KEIKI immediately.

<Low Flow Rate Abnormal Operations>

This alarm is triggered when the output value of the low flow sensor drops below the alarm setpoint. The alarm is auto-reset when the flow rate exceeds a certain level.

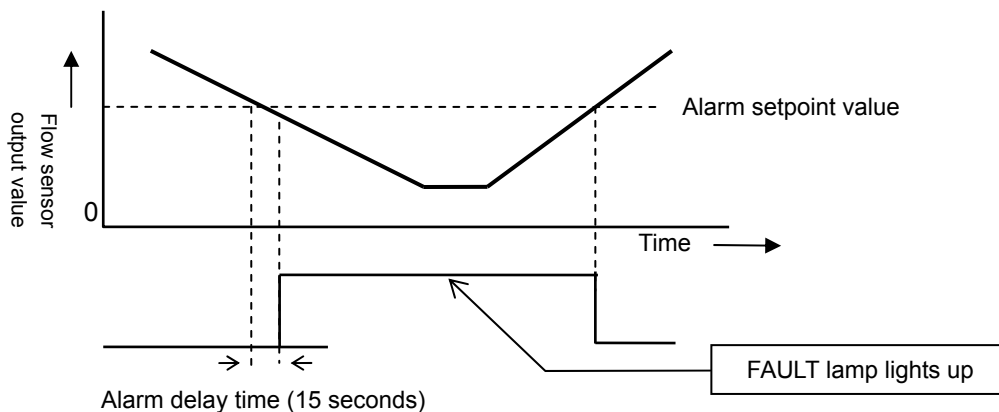

NOTE

- A low flow rate abnormality can be a cause of fault alarm.
For information on malfunctions (error messages), see "9. Troubleshooting".
- When a fault alarm is triggered, the indicator/alarm unit reports a sensor abnormality or fault alarm*.
* The display of an alarm depends on the indicator/alarm unit. For details, see the operating manual of the indicator/alarm unit.

7

Maintenance

The detector head is an important instrument for the purpose of safety.

To maintain the performance of the detector head and improve the reliability of safety, perform a regular maintenance.

Continuing to use the detector head without performing a maintenance will compromise the sensitivity of the gas sensor, thus resulting in inaccurate detection.

7-1. Maintenance intervals and items

- Daily maintenance: Perform maintenance before beginning to work.
- Monthly maintenance: Perform alarm test once a month.
- Regular maintenance: Perform maintenance once or more every six months to maintain the performance as a safety unit.

Maintenance item	Maintenance content	Daily maintenance	Monthly maintenance	Regular maintenance
Power lamp check	Check that the power lamp lights up.	○	○	○
Status display check	Check that the status display is "run" and that the fault lamp is off.	○	○	○
Flow rate check	Check that the float of the dust removal filter with flow monitor is visible.	○	○	○
Gas concentration display*	Check that the gas to be detected does not remain near the detector head (sampling point) and that the reading is normal.	○	○	○
Alarm test*	Check the alarm circuit by using the alarm test function.	-	○	○
Span adjustment*	Perform the sensitivity calibration by using the calibration gas.	-	-	○
Gas alarm check*	Check the gas alarm by using the calibration gas.	-	-	○
Flow sensor check	Check the flow sensor by using the test pump.	-	-	○

* Check and adjust at the indicator/alarm unit side. For details, see the operating manual of the indicator/alarm unit.

<About Maintenance Services>

- We provide services on regular maintenance including span adjustment, other adjustments and maintenance.

To make the calibration gas, dedicated tools, such as a gas cylinder of the specified concentration and gas sampling bag must be used.

Our qualified service engineers have expertise and knowledge on the dedicated tools used for services, along with other products. To maintain the safety operation of the detector head, please use our maintenance service.

- The followings are typical maintenance services. For more information, please contact RIKEN KEIKI.

Main services

Power supply check	:	Checks the power supply voltage. Verifies that the power lamp lights up.
Status display check	:	Checks that the status display is "run" and that the fault lamp is off.
Concentration display check*	:	Verifies that the concentration display value is zero by using the zero gas. Performs the zero adjustment if the display value is incorrect.
Flow rate check	:	Checks the flow rate by using an external flow meter to check for abnormalities.
Filter check	:	Checks the dust filter for dust or clogging. Replaces a dirty or clogged dust filter.
Alarm test*	:	Inspects the alarm circuit by using the alarm test function. <ul style="list-style-type: none"> • Checks the alarm lamps. (Checks activation.) • Checks the external alarm. (Checks the activation of the external alarm, such as a buzzer.)
Span adjustment*	:	Performs the span adjustment by using the calibration gas.
Gas alarm check*	:	Checks the gas alarm by using the calibration gas. <ul style="list-style-type: none"> • Checks the alarm. (Checks the alarm activation when the alarm setpoint is reached) • Checks the delay time. (Checks time to delay until the alarm is triggered.) • Checks the alarm lamps. (Checks activation.) • Checks the external alarm. (Checks the activation of external alarms, such as a buzzer and reset signal.)
Cleaning and repair of device (visual diagnosis)	:	Checks dust or damage on surface, cover, or internal parts of the detector head, cleans and repairs such parts of the device. Replaces parts which are cracked or damaged.
Device operation check	:	Uses the keys to check the operation of functions and parameters.
Replacement of consumable parts	:	Replaces consumable parts, such as a sensor, filter and pump.

* Inspect and adjust the indicator/alarm unit.

7-2. Parts replacement

<Gas Sensor, Flow Sensor, and Pump Replacement>

Our service engineers need to replace and calibrate these parts. Please contact RIKEN KEIKI.

NOTE

The gas calibration using the standard gas is required after the gas sensor is replaced. Adjustment is required after the flow sensor or pump is replaced. Please contact RIKEN KEIKI.
As a guide, replace the sensors of the detector head with new ones every one to three years.

<Replacement of Regular Replacement Parts>

List of recommended regular replacement parts

Name	Maintenance intervals	Replacement intervals (year)	Quantity (pieces/unit)	Remarks
AC/DC converter	6 months	3 - 6 years	1	※
Flow sensor	6 months	2 years	1	※
Tubes	6 months	3 - 8 years	1	※
Pump unit	6 months	1 - 2 years	1	※
Chamber assembly	6 months	3 - 8 years	1	※
Sensor cap assembly	6 months	3 - 8 years	1	※

※After the part is replaced, the operation must be checked by a qualified service engineer.

For the stable operation of the detector and safety, ask a qualified service engineer to take care of replacement of the parts whose operation must be checked. Please contact our sales department.

NOTE

The above replacement intervals are recommendation only. The intervals may change depending on the conditions such as the operating environment. These intervals do not mean the warranty periods either. The result of the regular maintenance may determine when to replace the parts.

8

Storage, Relocation and Disposal

8-1. Procedures to store the detector head or leave it for a long time

The detector must be stored under the following environmental conditions.

- In a dark place under the normal temperature and humidity away from direct sunlight
- In a place where gases, solvents or vapors are not present

8-2. Procedures to relocate the detector head or use it again

When the detector head is relocated, select a new place in accordance with "4-2. Precautions for installation points" and "4-4. How to install".

For information on wiring, see "4-5. How to wire". The unpowered time must be minimized when the detector head is relocated.



CAUTION

When using a relocated or stopped/stored detector head again, do not forget to perform a gas calibration. For information on readjustment including a gas calibration, please contact RIKEN KEIKI.

8-3. Disposal of products

When the detector head is disposed of, it must be treated properly as an industrial waste in accordance with the local regulations.

Troubleshooting

The Troubleshooting does not explain the causes of all the malfunctions which occur on the detector head. This simply helps to find the causes of malfunctions which frequently occur. If the detector head shows a symptom which is not explained in this manual, or still has malfunctions even though remedial actions are taken, please contact RIKEN KEIKI.

<Abnormalities on Unit>

Symptom/Display	FAULT	Causes	Actions
<u>The power cannot be turned on.</u>	—	The wiring is not correct.	Connect the wiring properly.
		The terminal plate is removed.	Connect the terminal plate properly.
		Abnormalities/momentary blackout of power supply system	Provide the rated voltage. Take measures such as checking or adding the UPS, power supply line filter and insulation transformer.
		Cable abnormalities (open circuit/not connected/short circuit)	Check the wiring of detector head and related devices around it.
<u>Abnormal operations</u>	—	Disturbances by sudden surge noise, etc.	Turn off and restart the detector head. If such a symptom is observed frequently, take appropriate measures to eliminate the noise.
<u>Low flow rate abnormality</u> E-5	●	The flow rate is low.	The possible causes are deterioration or clogging of the pump or clogging of the tube. Check the flow rate.
		Faults of the flow sensor	Replace the sensor with a new one.
<u>System abnormalities</u> E-9	●	Abnormalities of ROM, RAM, or EEPROM inside of the detector head	Please contact RIKEN KEIKI.

<Abnormalities of Readings>

* Perform troubleshooting on it as well as the indicator/alarm unit. For details, see the operating manual of the indicator/alarm unit.

Symptoms	Causes	Actions
<u>The reading rises (drops) and it remains so.</u>	Drifting of sensor output	Perform the zero adjustment.
	Presence of interference gas	Disturbances by interference gases, such as solvents, cannot be eliminated completely. For information on actions such as removal filter, please contact RIKEN KEIKI.
	Slow leak	A very small amount of the gas to be detected may be leaking (slow leak). Because ignoring it may cause dangers, take a remedial measure, i.e., taking actions the same as those for the gas alarm.
	Environmental changes	Perform the zero adjustment.
<u>A gas alarm is triggered despite of no gas leak and no other abnormalities at the detection point.</u>	Presence of interference gas	Disturbances by interference gases, such as solvents, cannot be eliminated completely. For information on actions such as removal of filter, please contact RIKEN KEIKI.
	Disturbance by noise	Turn off and restart the detector head. If such a symptom is observed frequently, take appropriate measures to eliminate the noise.
	Sudden change in the environment	When the environment (temperature, etc.) changes suddenly, the detector head cannot adjust to it and is affected by it. In some cases, the detector head triggers an indication alarm. Because the detector head cannot be used under sudden and frequent environmental changes, you must take any preventive actions to eliminate them.
<u>Slow response</u>	Sensor sensitivity deterioration	Replace the sensor with a new one.
<u>Span adjustment impossible</u>	Improper calibration gas concentration	Use the proper calibration gas.
	Sensor sensitivity deterioration	Replace the sensor with a new one.

10

Product Specifications

10-1. List of specifications

[GD-D58•DC(TypeGP)] <ATEX Specifications>

Detection principle	Catalytic combustion type
Gas to be detected	Combustible gas
Detection method	Sample-drawing
Flow rate	1.0 L/min or more (at maximum suction pressure of 5.0 kPa <gauge pressure>)
Power display	POWER lamp on (green)
Fault alarm/self diagnosis	System abnormality/low flow rate
Fault alarm display	FAULT lamp on (yellow)/detail display
Fault alarm pattern	Non latching (Auto-reset)
Transmission system	Sensor direct output
Transmission cable	CVV, etc. (1.25sq) - 6-core
Power supply	24 VDC \pm 10%
Power consumption	Maximum 8.6 W
Cable connecting port	For pump power supply: Pressure proof packing gland (Compatible cables ϕ 9.0 - ϕ 16.0mm in outer diameter) or plug (When unused) For transmission: Pressure proof packing gland (Compatible cables ϕ 9.0 - ϕ 16.0mm in outer diameter) or plug (When unused)
Tube connecting port	Rc1/8 (O.D ϕ 8-1t half-union for Cu tube <Bs> supplied or half-union for SUS tube <SUS>)
Operating temperature	-20 - 53°C (at a constant condition)
Operating humidity	Below 95% RH (Non-condensing)
Structure	Wall mounting type (2B<50A> pipe installation supported), drip-proof and dust-proof performances (compliant to IP67 level)
Explosion-proof structure	Flame-proof enclosures
Explosion-proof class	II 2G Ex db II B+H2 T4 Gb
Dimension	Approx. 197 (W) x 286 (H) x 140 (D) mm (projection portions excluded)
Weight	Approx. 5.8 kg
Outer color	Munsell 7.5BG5/2

* Specifications subject to changes without notice.

[GD-D58•DC(TypeNC)] <ATEX Specifications>

Detection principle	New ceramic type
Gas to be detected	Combustible gas
Detection method	Sample-drawing
Flow rate	1.0 L/min or more (at maximum suction pressure of 5.0 kPa <gauge pressure>)
Power display	POWER lamp on (green)
Fault alarm/self diagnosis	System abnormality/low flow rate
Fault alarm display	FAULT lamp on (yellow)/detail display
Fault alarm pattern	Non latching (Auto-reset)
Transmission system	Sensor direct output
Transmission cable	CVV, etc. (1.25sq) - 6-core
Power supply	24 VDC \pm 10%
Power consumption	Maximum 8.6 W
Cable connecting port	For power supply: Pressure proof packing gland (Compatible cables ϕ 9.0 - ϕ 16.0mm in outer diameter) or plug (When unused) For transmission: Pressure proof packing gland (Compatible cables ϕ 9.0 - ϕ 16.0mm in outer diameter) or plug (When unused)
Tube connecting port	Rc1/8 (O.D ϕ 8-1t half-union for Cu tube <Bs> supplied or half-union for SUS tube <SUS>)
Operating temperature	-20 - 53°C (at a constant condition)
Operating humidity	Below 95% RH (Non-condensing)
Structure	Wall mounting type (2B<50A> pipe installation supported), drip-proof and dust-proof performances (compliant to IP67 level)
Explosion-proof structure	Flame-proof enclosures
Explosion-proof class	II 2G Ex db II B+H2 T4 Gb
Dimension	Approx. 197 (W) x 286 (H) x 140 (D) mm (projection portions excluded)
Weight	Approx. 5.8 kg
Outer color	Munsell 7.5BG5/2

* Specifications subject to changes without notice.

[GD-D58•AC(TypeGP)] <TIIS Specifications>

Detection principle	Catalytic combustion type
Gas to be detected	Combustible gas
Detection method	Sample-drawing
Flow rate	1.5 L/min or more (at maximum suction pressure of 5.3 kPa <gauge pressure>)
Power display	POWER lamp on (green)
Fault alarm/self diagnosis	System abnormality/low flow rate
Fault alarm display	FAULT lamp on (yellow)/detail display
Fault alarm pattern	Non latching (Auto-reset)
Transmission system	Sensor direct output
Transmission cable	CVV, etc. (1.25sq) - 6-core
Power supply	100 - 110 VAC \pm 10%, 50/60 Hz
Power consumption	Maximum 13 VA
Cable connecting port	For power supply: Pressure proof packing gland (Compatible cables ϕ 9.0 - ϕ 13.0mm, ϕ 16.0mm in outer diameter) or plug (When unused) For transmission: Pressure proof packing gland (Compatible cables ϕ 9.0 - ϕ 13.0mm, ϕ 16.0mm in outer diameter) or plug (When unused)
Tube connecting port	Rc1/8 (O.D ϕ 8-1t half-union for Cu tube <Bs> supplied or half-union for SUS tube <SUS>)
Operating temperature	-20 - 50°C (at a constant condition)
Operating humidity	Below 95% RH (Non-condensing)
Structure	Wall mounting type (2B<50A> pipe installation supported), drip-proof and dust-proof performances (compliant to IP67 level)
Explosion-proof structure	Flame-proof enclosures
Explosion-proof class	Ex d II B+H2 T4(TIIS<Japan>)
Dimension	Approx. 197 (W) x 286 (H) x 140 (D) mm (projection portions excluded)
Weight	Approx. 5.8 kg
Outer color	Munsell 7.5BG5/2

* Specifications subject to changes without notice.

[GD-D58•AC(TypeNC)] <TIIS Specifications>

Detection principle	New ceramic type
Gas to be detected	Combustible gas
Detection method	Sample-drawing
Flow rate	1.5 L/min or more (at maximum suction pressure of 5.3 kPa <gauge pressure>)
Power display	POWER lamp on (green)
Fault alarm/self diagnosis	System abnormality/low flow rate
Fault alarm display	FAULT lamp on (yellow)/detail display
Fault alarm pattern	Non latching (Auto-reset)
Transmission system	Sensor direct output
Transmission cable	CVV, etc. (1.25sq) - 6-core
Power supply	100 - 110 VAC $\pm 10\%$, 50/60 Hz
Power consumption	Maximum 13 VA
Cable connecting port	For power supply: Pressure proof packing gland (Compatible cables $\phi 9.0$ - $\phi 13.0$ mm, $\phi 16.0$ mm in outer diameter) or plug (When unused) For transmission: Pressure proof packing gland (Compatible cables $\phi 9.0$ - $\phi 13.0$ mm, $\phi 16.0$ mm in outer diameter) or plug (When unused)
Tube connecting port	Rc1/8 (O.D $\phi 8$ -1t half-union for Cu tube <Bs> supplied or half-union for SUS tube <SUS>)
Operating temperature	-20 - 50°C (at a constant condition)
Operating humidity	Below 95% RH (Non-condensing)
Structure	Wall mounting type (2B<50A> pipe installation supported), drip-proof and dust-proof performances (compliant to IP67 level)
Explosion-proof structure	Flame-proof enclosures
Explosion-proof class	Ex d II B+H2 T4(TIIS<Japan>)
Dimension	Approx. 197 (W) x 286 (H) x 140 (D) mm (projection portions excluded)
Weight	Approx. 5.8 kg
Outer color	Munsell 7.5BG5/2

* Specifications subject to changes without notice.

[GD-D58•DC(TypeGP)] <TIIS Specifications>

Detection principle	Catalytic combustion type
Gas to be detected	Combustible gas
Detection method	Sample-drawing
Flow rate	1.0 L/min or more (at maximum suction pressure of 5.0 kPa <gauge pressure>)
Power display	POWER lamp on (green)
Fault alarm/self diagnosis	System abnormality/low flow rate
Fault alarm display	FAULT lamp on (yellow)/detail display
Fault alarm pattern	Non latching (Auto-reset)
Transmission system	Sensor direct output
Transmission cable	CVV, etc. (1.25sq) - 6-core
Power supply	24 VDC \pm 10%
Power consumption	Maximum 8.6 W
Cable connecting port	For power supply: Pressure proof packing gland (Compatible cables ϕ 9.0 - ϕ 13.0mm, ϕ 16.0mm in outer diameter) or plug (When unused) For transmission: Pressure proof packing gland (Compatible cables ϕ 9.0 - ϕ 13.0mm, ϕ 16.0mm in outer diameter) or plug (When unused)
Tube connecting port	Rc1/8 (O.D ϕ 8-1t half-union for Cu tube <Bs> supplied or half-union for SUS tube <SUS>)
Operating temperature	-20 - 53°C (at a constant condition)
Operating humidity	Below 95% RH (Non-condensing)
Structure	Wall mounting type (2B<50A> pipe installation supported), drip-proof and dust-proof performances (compliant to IP67 level)
Explosion-proof structure	Flame-proof enclosures
Explosion-proof class	Ex d II B+H2 T4(TIIS<Japan>)
Dimension	Approx. 197 (W) x 286 (H) x 140 (D) mm (projection portions excluded)
Weight	Approx. 5.8 kg
Outer color	Munsell 7.5BG5/2

* Specifications subject to changes without notice.

[GD-D58•DC(TypeNC)] <TIIS Specifications>

Detection principle	New ceramic
Gas to be detected	Combustible gas
Detection method	Sample-drawing
Flow rate	1.0 L/min or more (at maximum suction pressure of 5.0 kPa <gauge pressure>)
Power display	POWER lamp on (green)
Fault alarm/self diagnosis	System abnormality/low flow rate
Fault alarm display	FAULT lamp on (yellow)/detail display
Fault alarm pattern	Non latching (Auto-reset)
Transmission system	Sensor direct output
Transmission cable	CVV, etc. (1.25sq) - 6-core
Power supply	24 VDC \pm 10%
Power consumption	Maximum 8.6 W
Cable connecting port	For power supply: Pressure proof packing gland (Compatible cables ϕ 9.0 - ϕ 13.0mm, ϕ 16.0mm in outer diameter) or plug (When unused) For transmission: Pressure proof packing gland (Compatible cables ϕ 9.0 - ϕ 13.0mm, ϕ 16.0mm in outer diameter) or plug (When unused)
Tube connecting port	Rc1/8 (O.D ϕ 8-1t half-union for Cu tube <Bs> supplied or half-union for SUS tube <SUS>)
Operating temperature	-20 - 53°C (at a constant condition)
Operating humidity	Below 95% RH (Non-condensing)
Structure	Wall mounting type (2B<50A> pipe installation supported), drip-proof and dust-proof performances (compliant to IP67 level)
Explosion-proof structure	Flame-proof enclosures
Explosion-proof class	Ex d II B+H2 T4(TIIS<Japan>)
Dimension	Approx. 197 (W) x 286 (H) x 140 (D) mm (projection portions excluded)
Weight	Approx. 5.8 kg
Outer color	Munsell 7.5BG5/2

* Specifications subject to changes without notice.

10-2. Detection principle

[Catalytic Combustion Type]

When a combustible gas burns on the surface of an oxidation catalyst, the catalytic combustion type sensor considers resultant combustion heat as temperature and resistance changes in the platinum wire coil, and measures their gas concentrations.

This sensor detects any combustible gases. The detection range is from zero to the lower explosive limit. When a high-concentrated gas over the lower explosive limit comes into contact with the sensor, it may be a break.

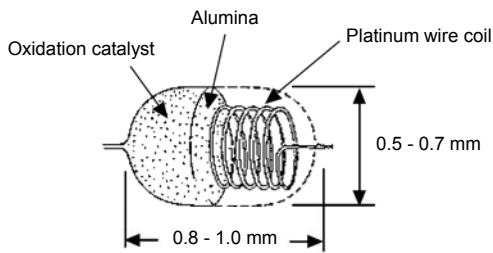

Structure Diagram

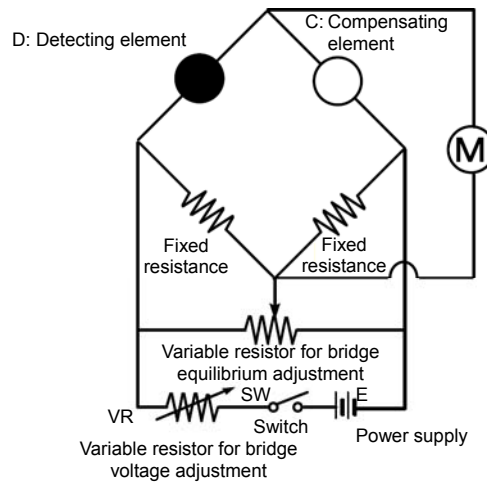

Basic Circuit

[New Ceramic Type]

When a combustible gas burns on the surface of a highly active new ceramic oxidation catalyst in catalytic combustion, the new ceramic-type sensor measures resultant temperature changes by measuring the resistance changes in the heat-resistant alloy wire coil.

The sensor consists of two elements: A detecting element having a heat-resistant alloy wire coil with an ultrafine particle (new ceramic) oxidation catalyst sintered on it together with a carrier and a temperature-compensating element with a mixture of gas-inert alumina and glass sintered on it.

When a combustible gas comes into contact with the surface of the detecting element with new ceramic oxidation catalyst sintered on it, the gas burns, causing the temperature to rise. In accordance with this temperature change, there occurs a change in the resistance of a heat-resistant alloy wire coil that constitutes the element. These resistance values are approximately proportional to gas concentrations. From the changes in the resistance values, potential differences are obtained using a bridge circuit and displayed as gas concentrations on the meter.

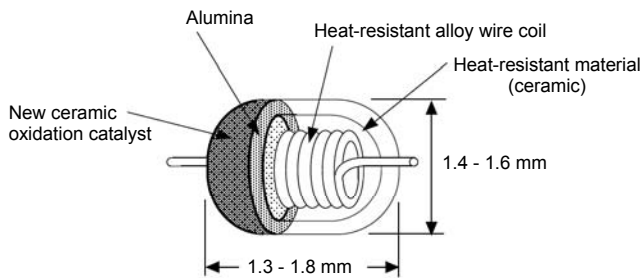

Structure Diagram

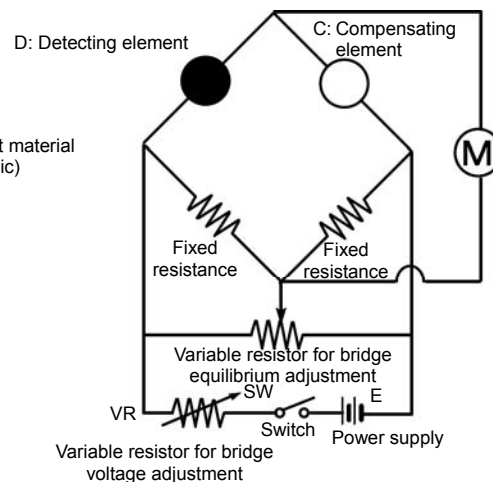

Basic Circuit

[Flow Sensor]

The flow sensor has a circuit that can output a contact signal when the flow rate drops below the preset level.

The flow sensor is a hot-wire type with a Wheatstone bridge consisting of a detecting element, compensating element, and fixed resistance. Contained in a flame arrester container allows it to be flame-proof.

When the drawn air or gas comes into contact with the heated detecting element, the detecting element temperature changes due to the heat dissipation, and the electrical resistance of the element changes according to the temperature changes. Since the resistance changes are in proportion to the gas flow rates, the Wheatstone bridge circuit can identify the changes as the flow rate.

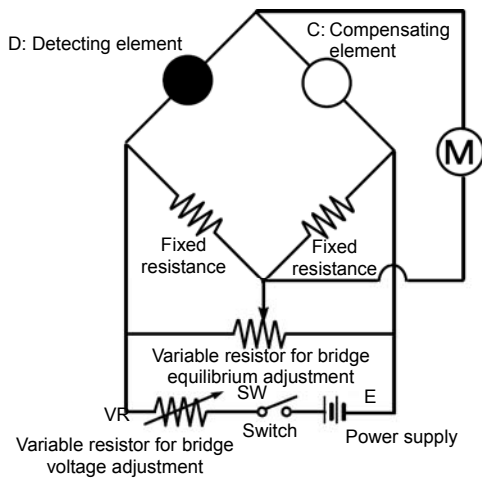

Basic Circuit

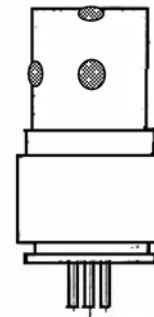

Flow Sensor Appearance

11

Definition of Terms

Catalytic combustion type	This is a principle of the sensor installed in the Type GP. See "10-2. Detection principle" for details.
New ceramic	This is a principle of the sensor installed in the Type NC. See "10-2. Detection principle" for details.
Initial clear	Output from the detector head fluctuates for a while after turning on the power. This is a function to prevent triggering alarm during that time.
Full scale	Maximum value of the detection range.
%LEL	A unit which the lower explosive limit (LEL) of the combustible gas to be detected is set to 100.
ppm	A concentration unit that means part per million of the combustible gas to be detected.
Calibration	Adjusts the readings to the calibration gas concentration value by using the calibration gas.

Declaration of Conformity

We, **RIKEN KEIKI CO., LTD.**

2-7-6, Azusawa, Itabashi-ku,
Tokyo 174-8744 Japan

declare in our sole responsibility that the following product conforms to all the relevant provisions.

Product Name	:	Gas Detector
Model Name	:	SD-D58-DC, GD-D58-DC, RP-D58-DC SD-D58-DC-GH, GD-D58-DC-GH
Council Directives	:	EMC : 2014/30/EU ATEX : 2014/34/EU
Applicable Standards	:	RoHS : 2011/65/EU EMC : EN 50270:2006 ATEX : EN 60079-0:2012:A11:2013,Corr3 EN 60079-1:2014 RoHS : EN 50581(2012)
Name and address of the ATEX Notified Body	:	Certification Management Limited (NB 2503) Unit 1 Newport Business Park New Port Road Ellesmere Port CH65 4LZ UK
Number of the EU type examination certificate	:	CML 15ATEX1033 12 May 2017
Name and address of the ATEX Auditing Organization	:	SGS Baseefa Ltd. (NB 1180) Rockhead Business Park Staden Lane SK17 9RZ BUXTON United Kingdom

The Marking of the equipment or protective system shall include the following : II 2G Ex db II B+H2 T4 Gb

Year to begin affixing CE Marking : 2017

Place: TOKYO, Japan

Signature: 
Full name: Tetsuya Kawabe

Date: May.16, 2017

Title: Director, Quality control center