



Fixed Combustible/ Toxic Gas Detector Head

GD-A80 Series

GD-A80, GD-A80D

GD-A80V, GD-A80DV

GD-A80S, GD-A80DS

GD-A80N, GD-A80DN

Operating Manual

RIKEN KEIKI Co., Ltd.

2-7-6 Azusawa, Itabashi-ku, Tokyo, 174-8744, Japan

Phone : +81-3-3966-1113

Fax : +81-3-3558-9110

E-mail : intdept@rikenkeiki.co.jp

Web site : <https://www.rikenkeiki.co.jp/>

Operating Precautions

This detector is a gas detector that detects combustible or toxic gases in the air and triggers a gas alarm.

The gas detector is a safety unit, not an analyzer or densitometer which performs quantitative/qualitative analysis/measurement for gases. Please fully understand the following points before using it, so that it can be used properly.

1. This detector may be interfered by gases other than the gas to be detected and vapors. Please note that the alarm may be triggered by interference. In addition, it may be fluctuated by environmental (temperature, humidity, etc.) changes in the installation site.
2. The alarm must be set within a range where the performance of the detector can be ensured. In facilities compliant with the High Pressure Gas Safety Act, an alarm setting below our standard alarm setpoint may trigger a false alarm.
3. This is a safety unit, not a control unit.
4. If silicon or sulfide compounds are accumulated on the surface of sintered alloy of the gas detector sensor used for this unit, the area of the gas sensing part becomes smaller, which may result in serious deterioration of its sensitivity.
For safety reasons, do not use the detector under the presence of silicon or sulfide compounds even though their amount is very small.
5. For maintenance of the detector, it must go through a regular maintenance, including replacement and adjustment of the regular replacement parts as specified in the operating manual. In addition, because this is a safety unit, it is recommended that a regular maintenance and a calibration are performed every six months in accordance with the regulations.

Contents

1	Outline of the Product	4
1-1.	Preface.....	4
1-2.	Purpose of use.....	4
1-3.	Definition of DANGER, WARNING, CAUTION and NOTE.....	4
1-4.	ethod of confirmation for Standards and Explosion proof specification.....	5
2	Important Notices on Safety.....	6
2-1.	Danger cases.....	6
2-2.	Warning cases	7
2-3.	Precautions	8
2-4.	Safy information	9
3	Product Components	11
3-1.	Main unit and standard accessories	11
4	How to Use.....	13
4-1.	Before using the detector.....	13
4-2.	Precautions for installation sites	13
4-3.	Precautions for system designing.....	14
4-4.	How to install.....	16
4-5.	Installation procedure	17
4-6.	How to wire	19
4-7.	How to tube (* For suction type)	23
5	How to Operate	24
5-1.	Preparation for start-up.....	24
5-2.	How to start the detector.....	24
5-3.	How to detect.....	24
5-4.	How to exit	25
6	Maintenance.....	26
6-1.	Maintenance intervals and items	26
6-2.	Calibration method.....	28
6-3.	Replacement parts.....	30
7	Storage, Relocation and Disposal.....	32
7-1.	Procedures to store the detector or leave it for a long time.....	32
7-2.	Procedures to relocate the detector or use it again.....	32
7-3.	Disposal of products	32
8	Troubleshooting	33
9	Product Specifications	35
9-1.	Standard specifications.....	35
9-2.	Detection principle	39
10	Definition of Terms	42

1

Outline of the Product

1-1. Preface

Thank you for choosing our fixed combustible/toxic gas detector head GD-A80 series. Please check that the model number of the product you purchased is included in the specifications on this manual.



This manual explains how to use the detector and its specifications. It contains information required for using the detector properly. Not only the first-time users but also the users who have already used the product must read and understand the operating manual to enhance the knowledge and experience before using the detector.

Note that the detector cannot be used alone. Use it with the dedicated indicator/alarm unit. Be sure to read the operating manual of the indicator/alarm unit as well.

1-2. Purpose of use

- This detector is a fixed type gas detector head which detects leak of combustible or toxic gases.
- The detector is a safety unit, not an analyzer or densitometer which performs quantitative/qualitative analysis/measurement for gases.
Please fully understand the features of the detector before using it, so that it can be used properly.
- The detector detects abnormalities caused by presence of gases (leak) with the built-in gas sensor.
- The suction type of the detector uses an external pump, etc. to introduce gas and performs gas detection.
- Use the detector in combination with an indicator/alarm unit that indicates a gas concentration and triggers an alarm.
- When the detector detects a leak of combustible or toxic gas, it outputs a voltage according to the gas concentration. The indicator/alarm unit indicates the gas concentration and triggers an alarm if a preset concentration level is exceeded.

1-3. Definition of DANGER, WARNING, CAUTION and NOTE

 DANGER	This message indicates that improper handling may cause serious damage on life, health or assets.
 WARNING	This message indicates that improper handling may cause serious damage on health or assets.
 CAUTION	This message indicates that improper handling may cause minor damage on health or assets.
NOTE	This message indicates advice on handling.

2

Important Notices on Safety

2-1. Danger cases

**DANGER**

<About explosion-proof>

- Do not attempt to repair the detector.
- Do not open the lid when applying current.
- For the lid, use hexagon socket head bolts specified by RIKEN KEIKI.
- If a scratch, crack or other abnormality is found on the container or explosion-proof structure joint surface, stop using the detector immediately and contact RIKEN KEIKI.

2-2. Warning cases



WARNING

Need of grounding circuit

Do not cut the grounding circuit or disconnect the wire from the grounding terminal.

Defects in protective functions

Before starting the detector, check the protective functions for defects. When seeming defects are found in the protective functions, such as protective grounding, do not start the detector.

Tube*

The detector is designed to draw gases under the atmospheric pressure. Be sure that excessive pressure is not applied to the sampling inlet and outlet (GAS IN, GAS OUT) of the detector. Detected gases must be exhausted from the detected gas exhausting outlet (GAS OUT) to which an exhaust tube is connected, to a point regarded as a safe place.

Zero adjustment in the atmosphere

When the zero adjustment is performed in the atmosphere, check the atmosphere for freshness before beginning the adjustment. If interference gases exist, the adjustment cannot be performed properly, thus leading to dangers when the gas leaks.

Do not install the detector in a place where silicone, chloride or sulfide is present consistently.

If the detector is installed in such a place, the sensor life will be shortened significantly due to poisoning, resulting in a dangerous situation where proper gas detection cannot be performed.

Response to gas alarm

Issuance of a gas alarm indicates that there are extreme dangers. Take proper actions based on your judgment.

* Suction type only

2-3. Precautions



CAUTION

Do not use a transceiver or other radio wave transmitting device near the detector.

Radio wave from a transceiver, etc. near the detector or its cables may disturb operations. If a transceiver or other radio wave transmitting device is used, it must be used in a place where it disturbs nothing.

Verify that the flow rate corresponds to the specified flow rate before using the detector.*

If it does not correspond to the specified flow rate, gas detection cannot be performed properly. Check whether the flow rate is unstable or lost.

Attach the dust filter before using the detector.*

Before using the detector, attach the specified filter to prevent disturbances by possible gas adsorption or air dust.

A dust filter to be used varies depending on the gas to be detected. For more information on dust filters, please contact RIKEN KEIKI.

Observe the operating restrictions to prevent condensation inside the tube.*

Condensation formed inside the tube causes clogging or gas adsorption, which may disturb accurate gas detection. Thus, condensation must be avoided. In addition to the installation environment, carefully monitor the temperature/humidity of the sampling point to prevent condensation inside the tube. In particular, when detecting a gas which is dissolved into water and corrodes contacted materials, such as a strong acid gas, the gas is undetectable and furthermore may corrode internal parts. Please observe the operating restrictions.

Do not disassemble/modify the detector.

Disassembling/modifying the detector will invalidate the warranty of the performance. Please use the detector properly in accordance with the operating manual.

Never fail to perform a regular maintenance.

Since this is a safety unit, a regular maintenance must be performed to ensure safety. Continuing to use the detector without performing a maintenance will deteriorate the sensitivity of the sensor, thus resulting in inaccurate gas detection.

Do not use the detector under an inert gas atmosphere.

GD-A80(D)N is an exception.

* Suction type only

2-4. Safety Information

Necessary information for explosion proof construction of Model GD-A80 series.

This product is diffusion gas detector which is called type GD-A80, and used in connection with indication alarm.

This product also can be used as suction gas detector, type GD-A80D by attaching suction chamber.

<ATEX/IECEX Specifications>

Technical Data

(Protection Method)	Flameproof enclosure “d”
(Group)	II
(Category)	2G
(Type of Protection and Marking code)	Ex db IIC T4 Gb
(Equipment Protection Level)	Gb
(Ambient Temperature)*	-40°C to +53°C
(Electrical Data)	

Electrical rating :	GD-A80(D)	DC3.0V 430mA or DC5.0V 200mA
	GD-A80(D)V	DC6.5V 205mA or DC3.5V 350mA
	GD-A80(D)S	DC3.0V 500mA or DC5.0V 200mA
	GD-A80(D)N	DC3.3V 170mA or DC1.0V 220mA

(Applicable Standard) EN 60079-0 : 2018, EN 60079-1: 2014
IEC60079-0 (2017), IEC60079-1 (2014-06)

*The ambient temperature range which maintain a capability of explosion proof of the label on the detector is -40~+53°C. However, the available operating temperature range is -20~+53°C.

Specific conditions of “X”-mark:

Regarding ATEX specification, the measuring function according to Annex II paragraph 1.5.5 of the Directive is not covered by this EU-type examination.

It shall comply with the requirements from the relevant European harmonized standards which provide guidance on the performance of gas detection equipment and safety devices.

The flameproof joints not intended to be repaired.

Installation

【DG-A80(D)／A80(D)S／A80(D)N】

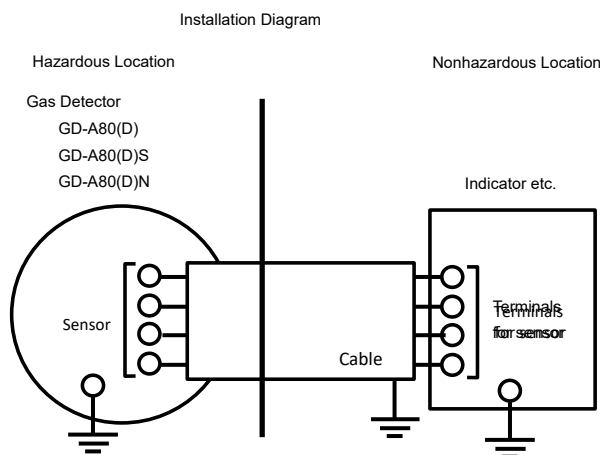

【GD-A80(D)V】

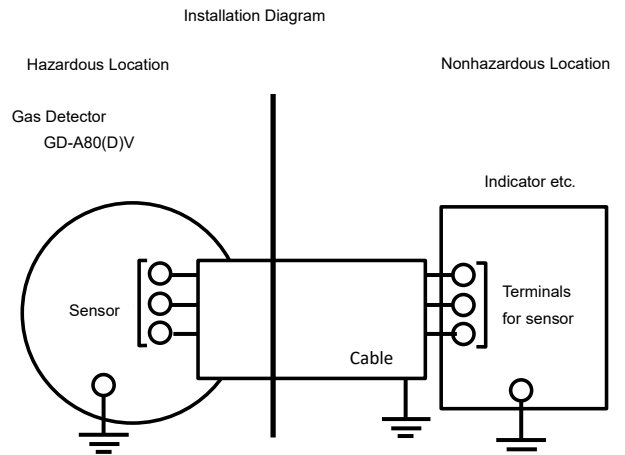

<TIIS Specifications>

Technical Data

(Protection Method)	Flameproof enclosure
(Explosion-proof class)	Ex d II C T4
(Ambient Temperature) *	-40°C to +53°C
(Electrical Data)	

Electrical rating :	GD-A80(D)	DC3.0V 430mA or DC5.0V 200mA
	GD-A80(D)V	DC6.5V 205mA or DC3.5V 350mA
	GD-A80(D)S	DC3.0V 500mA or DC5.0V 200mA
	GD-A80(D)N	DC3.3V 170mA or DC1.0V 220mA

(Applicable Standard) JNIOSH-TR-NO. 43(2008)

*The ambient temperature range which maintain a capability of explosion proof of the label on the detector is -40~+53°C. However, the available operating temperature range is -20~+53°C.

Installation

【DG-A80(D)／A80(D)S／A80(D)N】

【GD-A80(D)V】

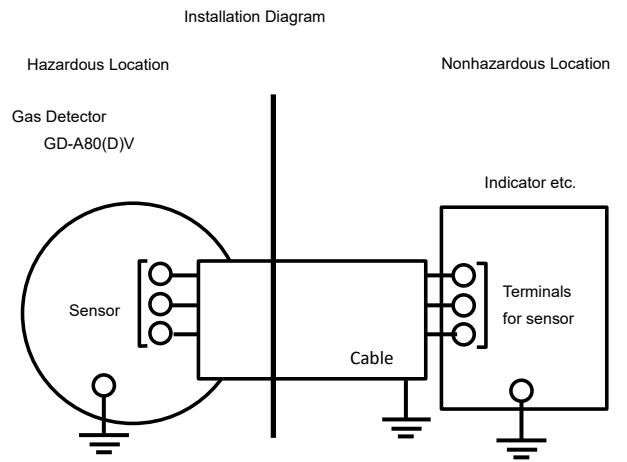
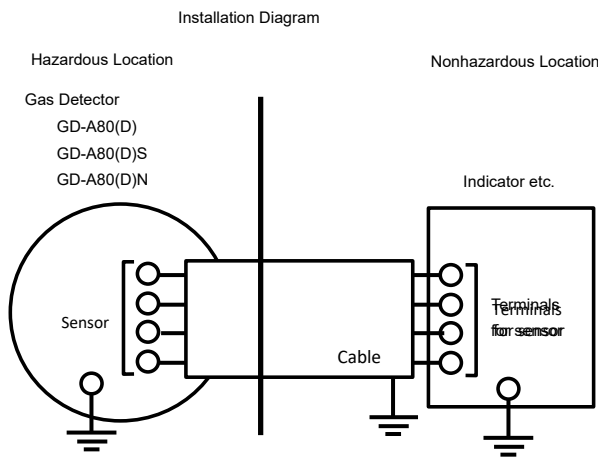

3

Product Components

3-1. Main unit and standard accessories

<Main Unit> (including a cable gland)
[Diffusion type]

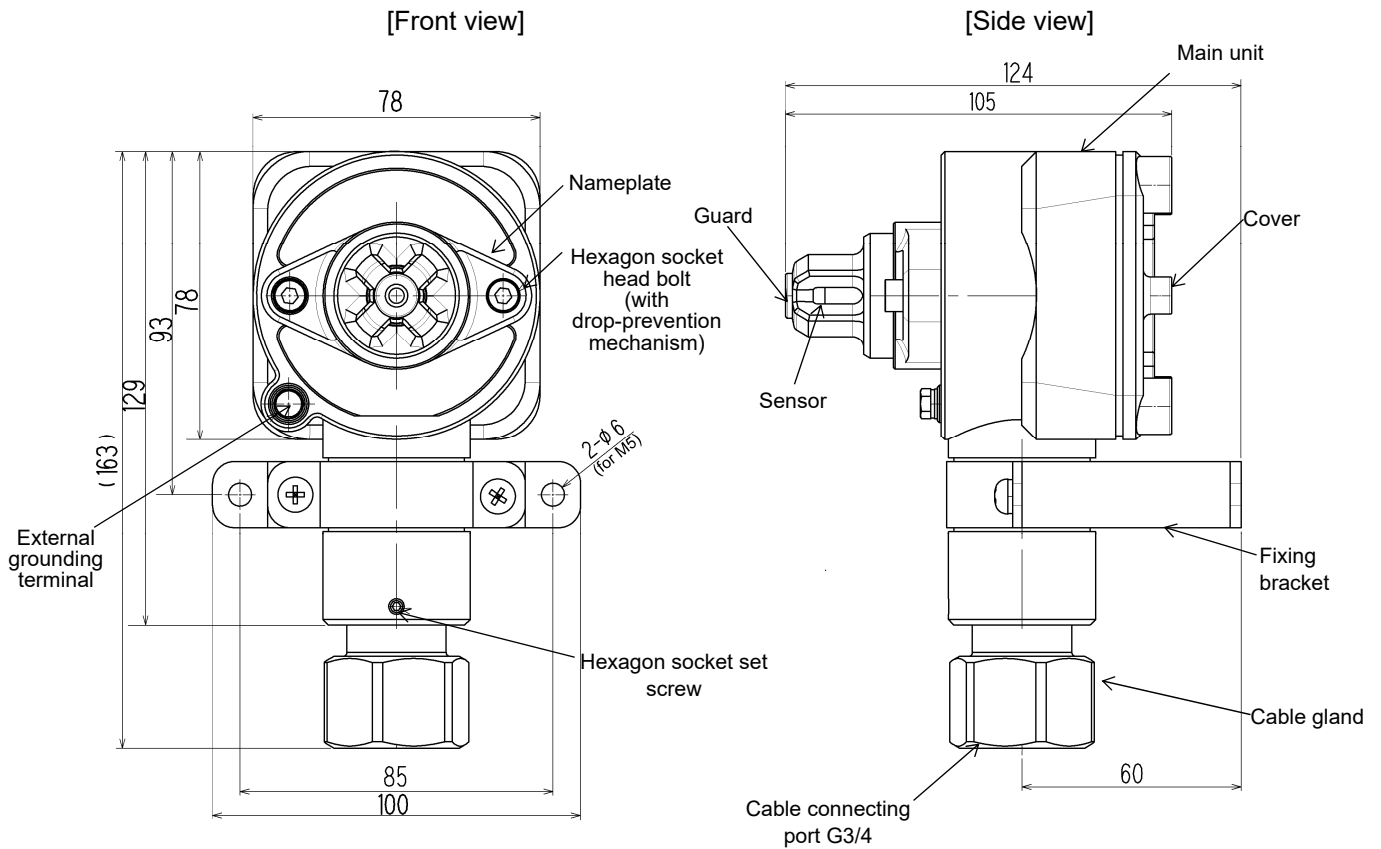

[Suction type]

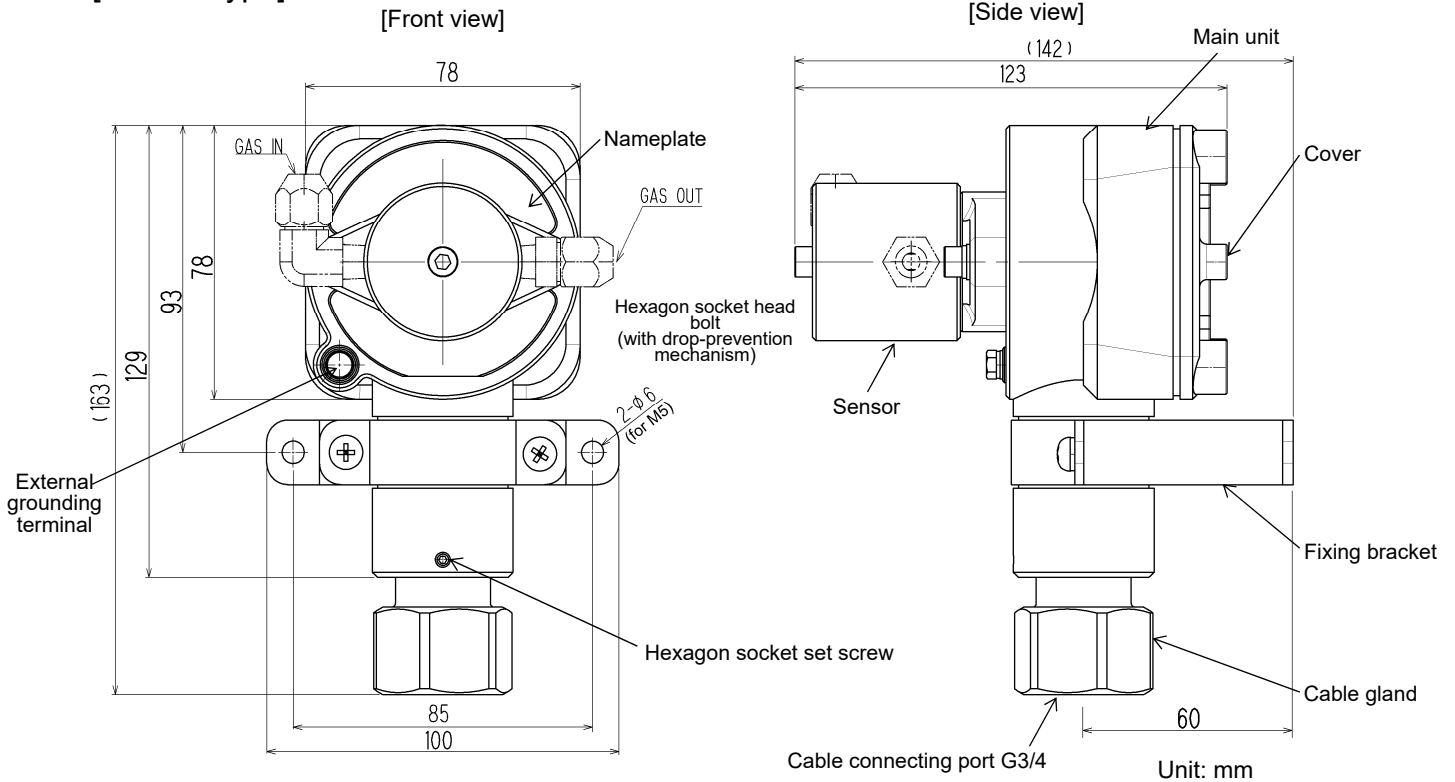

[Diffusion type and suction type]

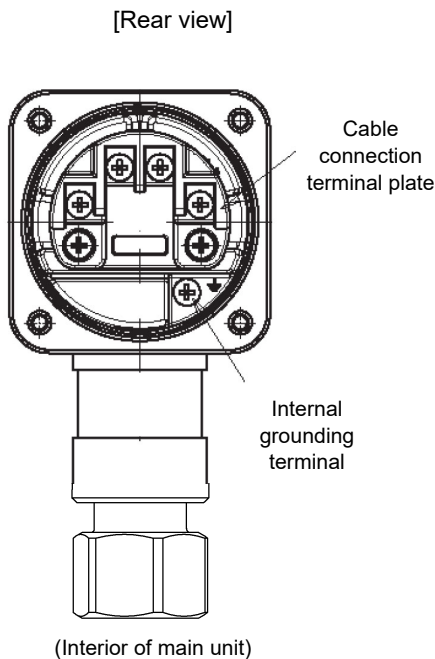

<Standard Accessories>

- Operating manual one
 - Fixing bracket one
 - Suction cap*1 one
 - Rubber seal (ID ϕ 12 mm)*2 one
 - Rubber seal (ID ϕ 13 mm) one
 - Washer (ID ϕ 12 mm)*2 one
 - Washer (ID ϕ 14 mm) one
 - Eccentric washer (ID ϕ 11.8 mm)*2 ... one
 - Eccentric washer (ID ϕ 12.8 mm) one
- *1. Attached to the suction type only.
 *2. Installed to the detector head as standard before shipment.

NOTE

- The nameplate on the front side of the detector shows the precautions to be taken for explosion-proof performances. Read these precautions as well as "2. Important Notices on Safety".

4

How to Use

4-1. Before using the detector

Not only the first-time users but also the users who have already used the detector must follow the operating precautions.

Ignoring the precautions may damage the detector, resulting in inaccurate gas detection.

The fixed combustible/toxic gas detector head GD-A80 series is used in combination with an indicator/alarm unit that indicates a gas concentration and triggers an alarm.

Once the detector detects a leak of combustible or toxic gas, it outputs a voltage according to the gas concentration. The indicator/alarm unit indicates the gas concentration and triggers an alarm if a preset concentration level is exceeded.

The detector may react to the gases other than the gases to be detected. When an alarm is triggered after gas detection, check if the cause of the alarm is attributable to the gases to be detected or other gases.

As a precondition, a gas detector needs to be energized always and operating normally to fulfill the role of detecting gases. To meet the precondition, it is important to check the daily operation status. For the check of operation status, see "6-1. Maintenance intervals and items".

4-2. Precautions for installation sites



CAUTION

- This is a precision device. Because the detector may not provide the specified performance in some places (environments), check the environment in the installation point, and then take appropriate actions if necessary.
- Because the detector plays an important role for safety and disaster prevention, as many units of the detector as needed must be installed in appropriate points. Because points where gases leak and remain easily are different depending on the types of gases and the working areas, please decide carefully on installation points and the number of units to be installed.

Do not install the detector in a place with vibrations or shocks.

The detector consists of sensitive electronic parts. The detector must be installed in a stable place without vibrations or shocks and it cannot drop.

Do not install the detector in a place exposed to water, oil or chemicals.

When selecting installation points, avoid a place where the detector is exposed to water, oil or chemicals.

Do not install the detector in a place where the range of operating temperatures is exceeded.

The detector must be installed in a stable place where the operating temperature is maintained and do not change suddenly.

Keep the sampling gas temperature within the range of -20 to +53°C.

Do not install the detector in a place exposed to direct sunlight or sudden changes in the temperature.

When selecting installation points, avoid a place where it is exposed to direct sunlight or radiant heat (infrared rays emitted from a high-temperature object), and where the temperature changes suddenly. Condensation may be formed inside the detector, or the detector cannot adjust to sudden changes in the temperature.

Keep the detector (and its cables) away from noise source devices.

When selecting installation points, avoid a place where high-frequency/high-voltage devices exist.

Do not install the detector in a place where maintenance of the detector cannot be performed or where handling the detector involves dangers.

Regular maintenance of the detector must be performed.

Do not install the detector in a place where the machinery must be stopped when maintenance is performed in its inside, where parts of the machinery must be removed to perform maintenance, or where the detector cannot be removed because tubes or racks, etc. prevent access to it. Do not install the detector in a place where maintenance involves dangers, for example, near a high-voltage cable.

Do not install the detector in machinery which is not properly grounded.

Before installing the detector in machinery, the machinery must be grounded properly.

Do not install the detector in a place where interference gases exist around it.

The detector must not be installed in a place where interference gases exist around it.



WARNING

- Do not install the detector in a place where silicone, chloride or sulfide is present consistently. If the detector is installed in such a place, the sensor life will be shortened significantly due to poisoning, resulting in a dangerous situation where proper gas detection cannot be performed.

4-3. Precautions for system designing



CAUTION

- An unstable power supply and noise may cause false alarms. The descriptions in this section must be reflected on the designing of a system using the detector.

Introducing protective measures against lightning

If cables are installed outside the factory/plant, or if internal cables are installed in the same duct as the cables coming from outside the factory/plant, "lightning" will cause problems. Because lightning acts as a large emission source while cables act as a receiving antenna, devices connected to the cables may be damaged.

Lightning cannot be prevented. Cables installed in a metal conduit or under the ground cannot be completely protected from inductive lightning surge caused by lightning. Although complete elimination of disasters caused by lightning is impossible, the following protective measures can be taken.

Protection against lightning	<p><u>Take appropriate measures in accordance with the importance of the facilities and the environment.</u></p> <ul style="list-style-type: none"> • Provide protection by a lightning arrester (cable arrester). (Although inductive lightning surge can be transmitted through the cable, it is prevented by installing a lightning arrester before the field devices and central processing equipment. For information on how to use a lightning arrester, please contact the manufacturer.)
Grounding	In addition to lightning, there are more sources of surge noise. To protect units from these noise sources, the units must be grounded.

- * The lightning arrester has a circuit to remove a surge voltage which damages field devices, so that signals may be attenuated by installing the arrester. Before installing a lightning arrester, verify that it works properly.

4-4. How to install

<Installation Dimensions>

[Diffusion type]

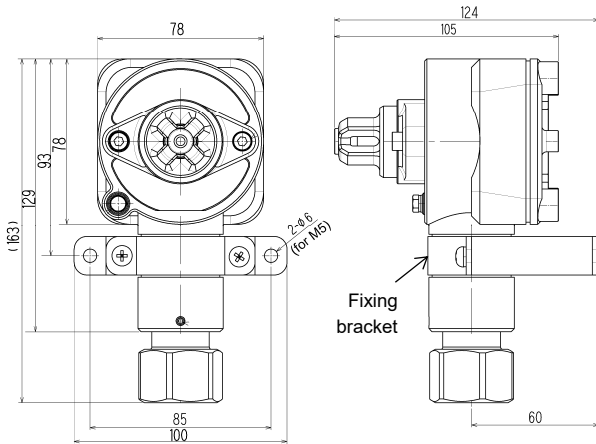

[Suction type]

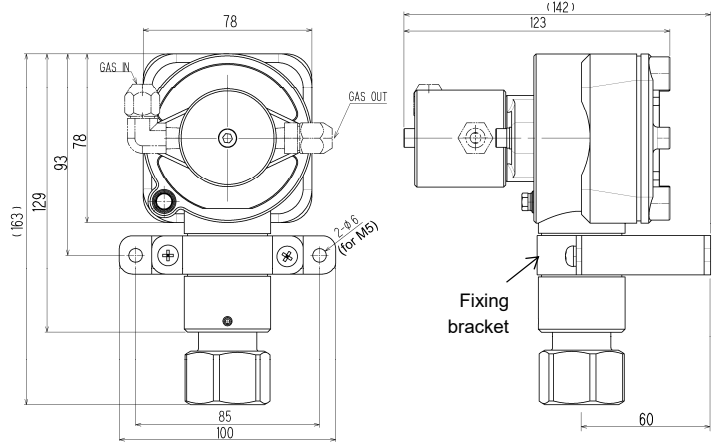

<Maintenance Space>

(Example) Diffusion type

* The same applies to the suction type.

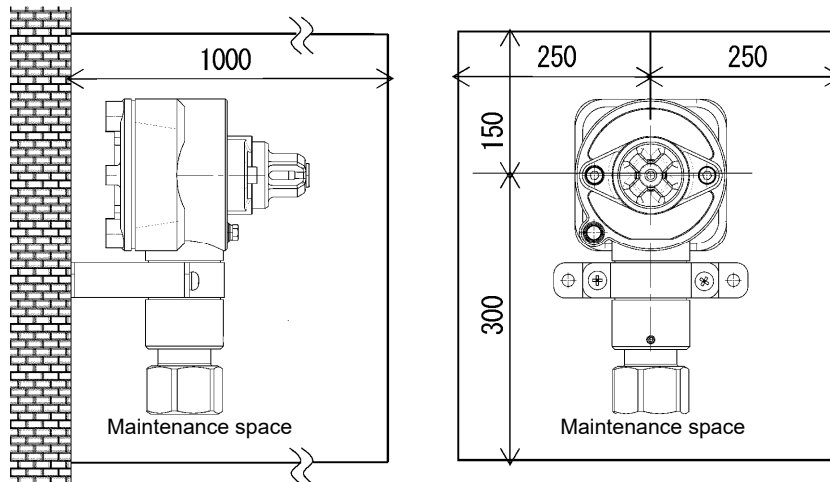

Unit: mm

The following installation requirements must be met to install the detector.

- Attach the detector to the wall or others using two M5 screws.



CAUTION

Do not install the detector in a place where maintenance of the detector cannot be performed or where handling the detector involves dangers.

Regular maintenance of the detector must be performed.

Do not install the detector in a place where the machinery must be stopped when maintenance is performed in its inside, where parts of the machinery must be removed to perform maintenance, or where the detector cannot be removed because tubes or racks, etc. prevent access to it. Do not install the detector in a place where maintenance involves dangers, for example, near a high-voltage cable.

4-5. Installation procedure

(1) Attach the cable gland, rubber seal, washer and eccentric washer to the main unit of GD-A80 series as shown in the following figure.

Put the cable through the cable gland, eccentric washer, washer and rubber seal in this order.

Then draw the cable into the detector head and attach a crimped terminal for M4 screw to the end of the cable (CVV, etc.). For the wiring method, see "4-6. How to wire".

Diffusion type

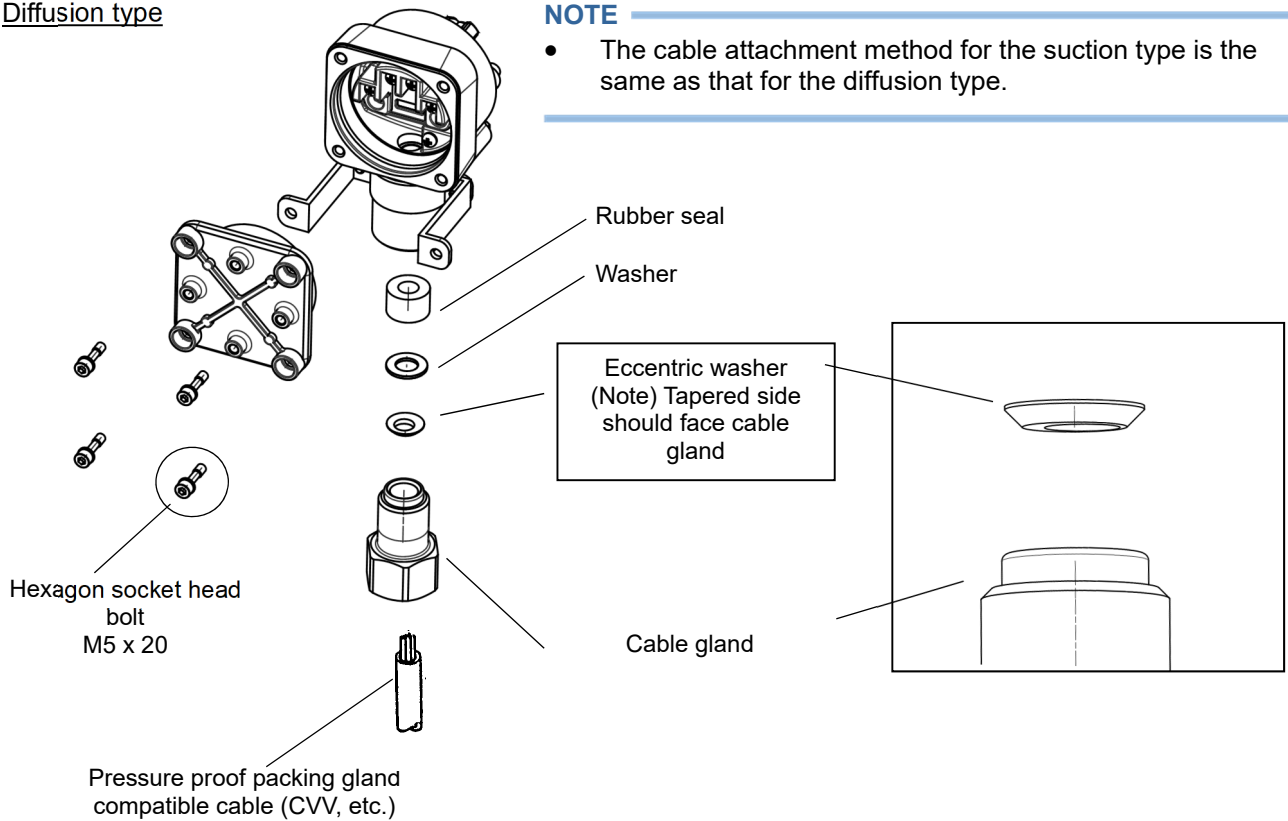

WARNING

- If a scratch, crack or other abnormality is found on the container or explosion-proof structure joint surface, stop using the detector immediately and contact RIKEN KEIKI.



CAUTION

- If it is difficult to tighten the cable gland, grease its screw part and then tighten it with the tool.

- (2) Tighten the cable gland with a tightening torque of at least 30 N·m. Then tighten the hexagon socket set screw to fix the cable gland.

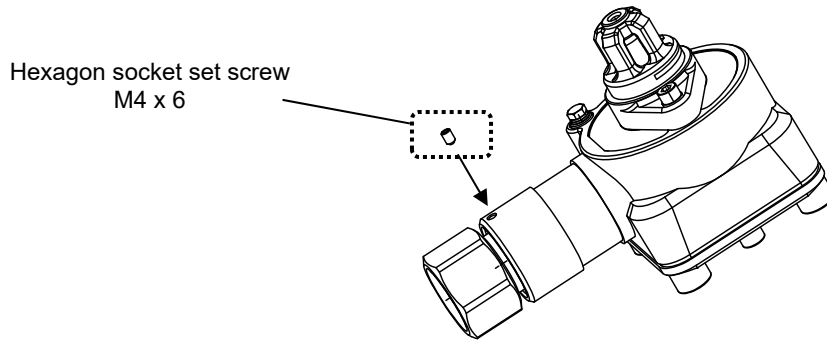

<Drip-proof Cover>

Two optional drip-proof covers (round and square drip-proof covers) are available for the GD-A80 series. Select an appropriate cover for the installation environment. Use a square drip-proof cover for an inferior environment condition such as a place with a risk of water splash. Use a round drip-proof cover when the detector is used on a ship.

[Round drip-proof cover]

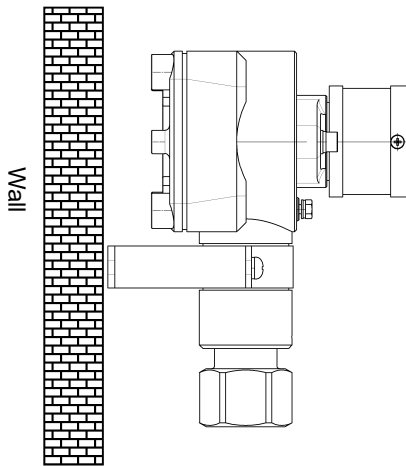

[Square drip-proof cover]

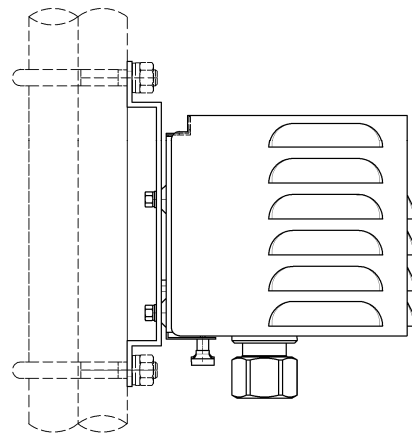

<Direct insert Unit> * Only diffusion type can be installed.

Direct insert unit is available as an option for combustible gas and solvent vapor detection in the duct.

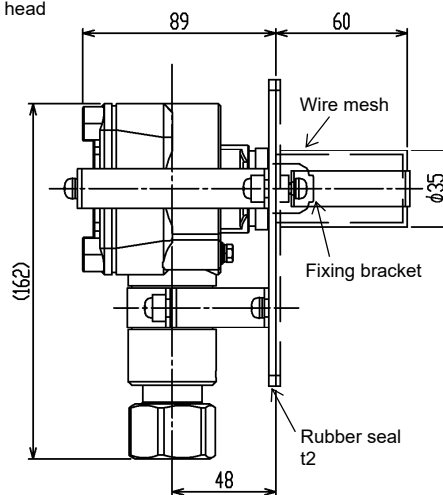
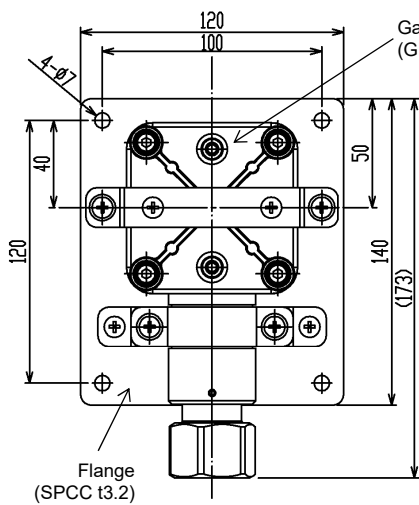

[Panel cut dimension]

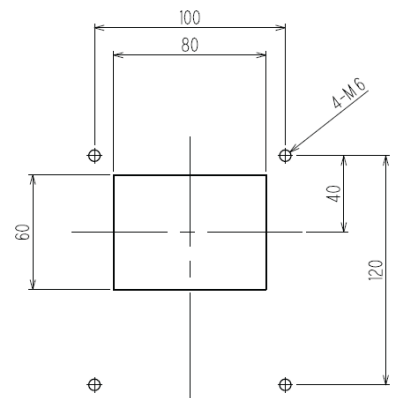

Unit:mm

4-6. How to wire

NOTE

- Before wiring, read also the operating manual of the indicator/alarm unit to be connected carefully.



WARNING

- Do not put a metal object or other foreign substances inside the external connection terminal box when attaching the lid. Ignoring this may damage the device or impair the explosion-proof performance.
- Draw the cable to the detector by the means that do not impair the explosion-proof performance.
- Connect the power to the indicator/alarm unit after all wiring work is completed. Wiring with the power connected may pose a risk of short circuit between terminals or electric shock.



CAUTION

- When wiring, be careful not to apply stresses on the detector when (overweight) cables are installed.
- The cables must not be installed together with the motor power cables, etc. When these cables must be installed together for unavoidable reasons, use a metal conduit. The conduit must be connected to a grounding circuit.
- When stranded wires are used, prevent wires from contacting each other.
- Use appropriate cables to wire.

<Recommended Cables>

GD-A80(D)	CVV or equivalent cable (1.25 or 2 mm ²), 4-core
GD-A80(D)V	CVVS or equivalent cable (1.25 or 2 mm ²), 3-core
GD-A80(D)S	CVVS or equivalent cable (1.25 or 2 mm ²), 4-core
GD-A80(D)N	CVVS or equivalent cable (1.25 or 2 mm ²), 4-core

<Parts. Length table of outside conductor lead-in>

Cable overall outer diameter (mm)	Rubber seal inner diameter (mm)	Washer inner diameter (mm)	Eccentric washer (mm)
ø 9.5 - 10.5	ø11	ø12	ø10.8
ø10.5 - 11.5	ø12	ø12	ø11.8
ø11.5 - 12.5	ø13	ø14	ø12.8
ø12.5 - 13.0	ø13.5	ø14	ø13.8

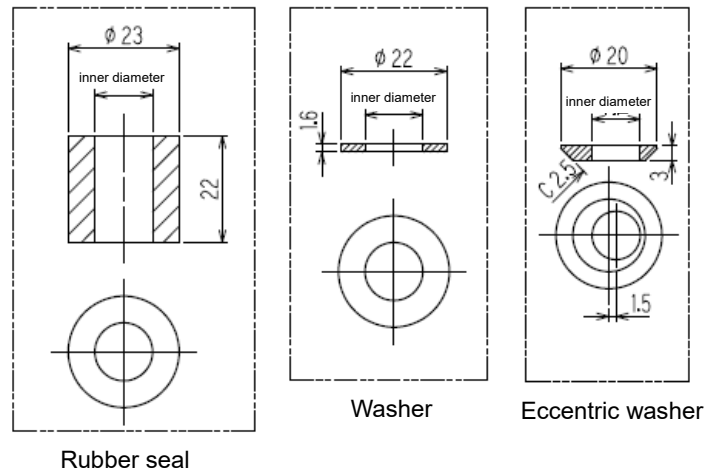

NOTE

- The following table shows an example of overall outer diameters of cables. Use them for reference. The overall outer diameters must be checked because they somewhat vary between manufacturers.

Number of core	CVV 1. 25 mm ²	CVV 2 mm ²	Use CVVS 1. 25 mm ²	CVVS 2 mm ²
2	$\phi 9.2$	$\phi 10.5$	$\phi 9.6$	$\phi 10.5$
3	$\phi 9.7$	$\phi 11.0$	$\phi 10.5$	$\phi 11.0$
4	$\phi 10.5$	$\phi 11.5$	$\phi 11.0$	$\phi 12.0$
5	$\phi 11.5$	$\phi 12.5$	$\phi 12.0$	$\phi 13.0$
6	$\phi 12.5$	$\phi 13.5$	$\phi 13.0$	$\phi 14.0$

- (1) The numbers 3, 4, 5 and 6 are shown on the terminal plate of the detector head. Perform wiring in the correct wiring order according to the following connection diagrams. When attaching the lid of the detector head, be careful not to squeeze the cable. (To make the work easier, fasten the cable gland temporarily to the detector head.)

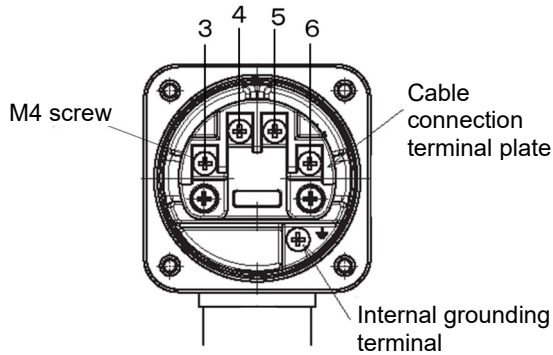

Screw size: M4

NOTE

- The cable connection terminal plate color varies by the model of the detector head.

Using 4-core cable: Black
 GD-A80(D)/A80(D)S/A80(D)N
 Using 3-core cable: White
 GD-A80(D)V

<Wiring Example>

[GD-A80(D)/A80(D)S/A80(D)N]

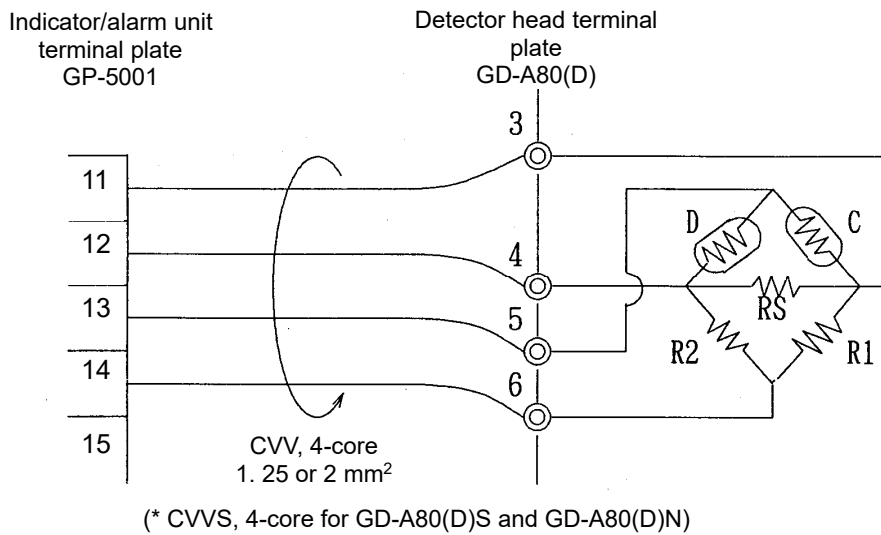

[GD-A80(D)V]

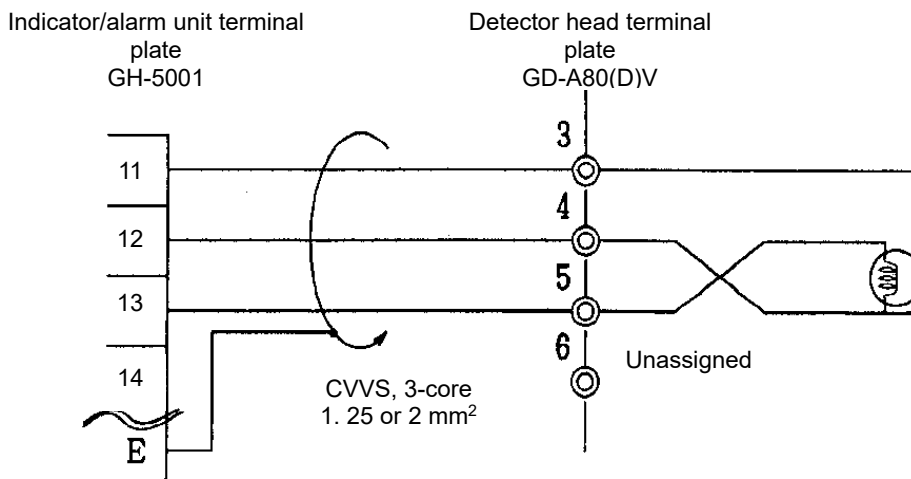

(2) Attach the lid of the detector head and tighten four hexagon socket head bolts securely.

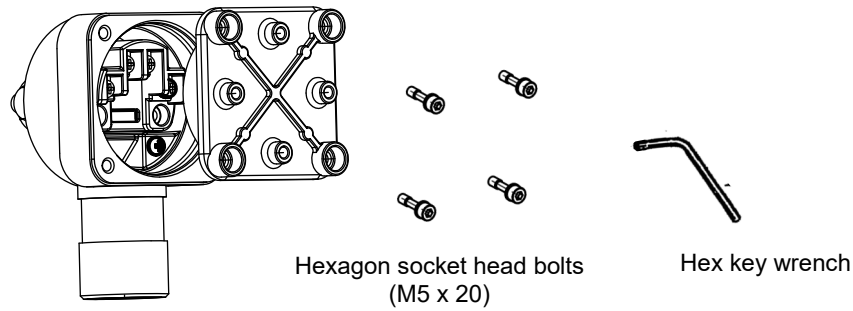

NOTE

- Hexagon socket head bolts with a grade of "A2-70" are used. Contact RIKEN KEIKI when the bolt is lost or replacement is necessary.



WARNING

- Be sure to use the bolts supplied with the unit to attach the lid of the detector head. Also, be sure to attach four bolts.
- Using the bolts other than those supplied with the unit will impair the explosion-proof performance.
- When wiring is completed, check for wrong wiring once again before turning on the power. If the power is turned on with wrong wiring, sensor disconnection will occur and the unit will become unavailable.

<Grounding>

Connect the detector to your grounding terminal with the external terminal .



WARNING

- Before turning on the detector, never fail to connect it to a grounding terminal.
- For stable operation of the detector and safety, it must be connected to a grounding terminal. Do not connect the grounding wire to a gas pipe.
- The grounding must be made as D type grounding (below 100 Ω of grounding resistance).
- For the grounding wire, use cable lugs to safely connect it to a grounding terminal without looseness or twist.
- To connect the grounding wire to the internal grounding terminal of the unit, use a crimped terminal to which a wire with a cross-section area of 4 mm² or more can be attached.

4-7. How to tube (* For suction type)

The detector has an Rc1/8 thread inside the sampling inlet/outlet (GAS IN, GAS OUT), to which one of "PP", "Bs" or "SUS" union is normally attached. Because their material varies depending on the gas to be used, please specify the appropriate unions.

The compatible tube is a tube of $\varnothing 6$ (OD) - $\varnothing 4$ (ID). The tube must be installed with the supplied inners and sleeves attached to prevent a leak.

When the tube is cut, its cut point has a smaller inner diameter. Use a file etc. to expand the inner diameter of the cut point. To remove cut-dust or other materials remaining inside of the tube, blow compressed air into the tube before connecting it to the detector.

Some sample gases have highly adsorptive or corrosive property. Select the tube material taking into account of these precautions. Note that the flow rate introduced to the detector is in the range of 0.8 - 2 L/min (the maximum pressure inside the flow path and sensor parts is 10.13 kPa <gauge pressure>).



WARNING

- The detector is designed to draw gases under the atmospheric pressure. Be sure that excessive pressure is not applied to the sampling inlet and outlet (GAS IN, GAS OUT) of the detector.
- Detected gases must be exhausted from the detected gas exhausting outlet (GAS OUT) to which an exhaust tube is connected, to a point regarded as a safe place.



CAUTION

- The longer the tube of the GAS IN is, the longer it takes for a gas to reach the detector. Because some gases have a highly adsorptive property for the tube, resulting in a slow response and a lower reading than the actual value, the length of the GAS IN tube must be minimized.
- When the humidity in the sampling point is high, condensation may be formed inside of the tube. Make sure to avoid condensation when using a gas which is dissolved into water and corrodes contacted materials, such as a strong acid gas, because it may disable the detector for detecting gas and furthermore may corrode internal parts. Also avoid an excessive U-shaped or V-shaped tube piping.
- Determine the inlet for the sample gas, considering the airflow of the sample gas line and the gas generating process.
- To remove dust, never fail to attach a dust filter in the middle of the tube.
- It is needed to decide the length and material of the tube. Please contact RIKEN KEIKI for more information.

5

How to Operate

5-1. Preparation for start-up

Before connecting a power supply, read and understand the following precautions. Ignoring these precautions may cause an electric shock or damage the detector.

- Check that the detector is installed properly.
- Connect the detector to a grounding circuit.
- Check that the external wiring is done properly.
- Check that there is no clogging or leak in the connected tube. If the connected tube is clogged, pressure is applied to the sensor, causing errors and malfunctions. (* For the case of suction type)
- Check that the filter is attached properly. The filter is specified based on the gas to be detected. (* For the case of suction type)

5-2. How to start the detector

Before supplying power to the detector, check that the preparations described in "5-1. Preparation for start-up" are completed. Turn on the indicator/alarm unit power and check that it functions normally with reference to the operating manual of the indicator/alarm unit.

5-3. How to detect

Turn on the power switch of the indicator/alarm unit. Gas detection starts after the initial clear.



CAUTION

- When the detector is installed newly or the sensor is replaced with new one, the sensor must be warmed up for a specified period which is determined depending on the type of the sensor after the detector is started.
- After the warm-up is completed, perform a calibration.

NOTE

- The semiconductor type and hot-wire semiconductor type sensors used for the detector require warm-up (energization) for a certain period of time after power-on. The warm-up (energization) time varies by the non-energizing time of the sensor. Perform warm-up according to the following table.

Unpowered time	Guidelines for warm-up (powered) time
24 hours or less	4 hours or more
72 hours or less	24 hours or more
10 days or less	2 days or more
Less than 1 month	7 days or more
Less than 3 months	14 days or more
3 months or more	1 month or more

5-4. How to exit

Turn off the power switch of the indicator/alarm unit.



WARNING

- When the detector is turned off, an alarm may be triggered on the upper (central) system.
- Before turning off the detector, INHIBIT (point skip) on the upper (central) system must be activated.

Also, check the operation of the devices connected to this gas leak detection/alarm system to see if power can be turned off.

6

Maintenance

The detector is an important instrument for the purpose of safety.

To maintain the performance of the detector and improve the reliability of safety, perform a regular maintenance.

Continuing to use the detector without performing maintenance will compromise the sensitivity of the gas sensor, thus resulting in inaccurate detection.

6-1. Maintenance intervals and items

- Daily maintenance: Perform maintenance before beginning to work.
- Monthly maintenance: Perform maintenance on the alarm circuit (alarm test) once a month.
- Regular maintenance: Perform maintenance once or more for every six months to maintain the performance as a safety unit.

Maintenance item	Maintenance content	Daily maintenance	Monthly maintenance	Regular maintenance
Power supply check ¹	Check that the power lamp lights up.	○	○	○
Status display check ¹	Check that the fault lamp does not light up.	○	○	○
Flow rate check ²	Check the flow rate to find abnormalities.	○	○	○
Concentration display check ¹	Check that the concentration display value is zero. When the reading is incorrect, perform the zero adjustment after ensuring that no interference gases exist around it.	○	○	○
Filter check ²	Check the dust filter for dust or clogging.	○	○	○
Alarm test ¹	Inspect the alarm circuit by using the alarm test function.	—	○	○
Span adjustment ¹	Perform the span adjustment by using the calibration gas.	—	—	○
Gas alarm check ¹	Check the gas alarm by using the calibration gas.	—	—	○

*1. Check and adjustment are performed at the indicator/alarm unit side. See the operating manual of the indicator/alarm unit for details.

*2. Suction type only



WARNING

- Since this is a safety unit, be sure to perform maintenance at least once every six months to ensure safety.
Continuing to use the detector without performing maintenance will compromise the sensitivity of the sensor of the detector head, thus resulting in inaccurate detection.

NOTE

- Before starting alarm test or span adjustment, be sure to provide a notification to the related sections and block external signals.

<About Maintenance Services>

- We provide services on regular maintenance including span adjustment, other adjustments and maintenance.
To make the calibration gas, dedicated tools, such as a gas cylinder of the specified concentration and gas sampling bag must be used.
Our service engineers have expertise and knowledge on the dedicated tools used for services, along with other products. To maintain the safety operation of the detector, please use our maintenance service.
- Typical maintenance services are listed as follows. For more information, please contact RIKEN KEIKI.

Main Services

Power supply check ^{*1}	:	Checks the power supply voltage. Verifies that the power lamp lights up.
Status check ^{*1}	:	Verifies that the fault lamp does not light up.
Concentration display check ^{*1}	:	Verifies that the concentration display value is zero by using the zero gas. Performs zero adjustment if the reading is incorrect.
Flow rate check ^{*2}	:	Checks the flow rate for abnormalities by using an external flow meter. If the flow rate is incorrect, performs the flow rate adjustment.
Filter check ^{*2}	:	Checks the dust filter for dust or clogging. Replaces a dirty or clogged dust filter.
Alarm test ^{*1}	:	Inspects the alarm circuit by using the alarm test function. <ul style="list-style-type: none"> • Checks the alarm lamp. (Checks ALM activation.) • Checks the external alarm. (Checks the activation of the external alarm, such as a buzzer.)
Span adjustment ^{*1}	:	Performs the span adjustment by using the calibration gas.
Gas alarm check ^{*1}	:	Checks the gas alarm by using the calibration gas. <ul style="list-style-type: none"> • Checks the alarm. (Checks triggering of alarm when the alarm setpoint is reached.) • Checks the delay time. (Checks time to delay until the alarm is triggered.) • Checks the alarm lamp. (Checks ALM activation.) • Checks the external alarm. (Checks the activation of external alarms, such as a buzzer and reset signal.)
Cleaning and repair of the unit (visual diagnosis)	:	Checks dust or damage on the surface, cover or internal parts of the unit, and cleans or repairs such parts as needed. Replaces parts which are cracked or damaged.
Unit operation check ^{*1}	:	Uses the keys to check the operation of functions and parameters.
Replacement of consumable parts	:	Replaces consumable parts, such as a sensor, filter and pump.

*1. Check and adjustment are performed at the indicator/alarm unit side.

*2. Suction type only

6-2. Calibration method

Perform a calibration with the indicator/alarm unit (zero adjustment/span adjustment mode) using the calibration gas.

- Zero adjustment gas
- Calibration gas (collected in a gas sampling bag)
- Gas sampling bag for exhaust gas

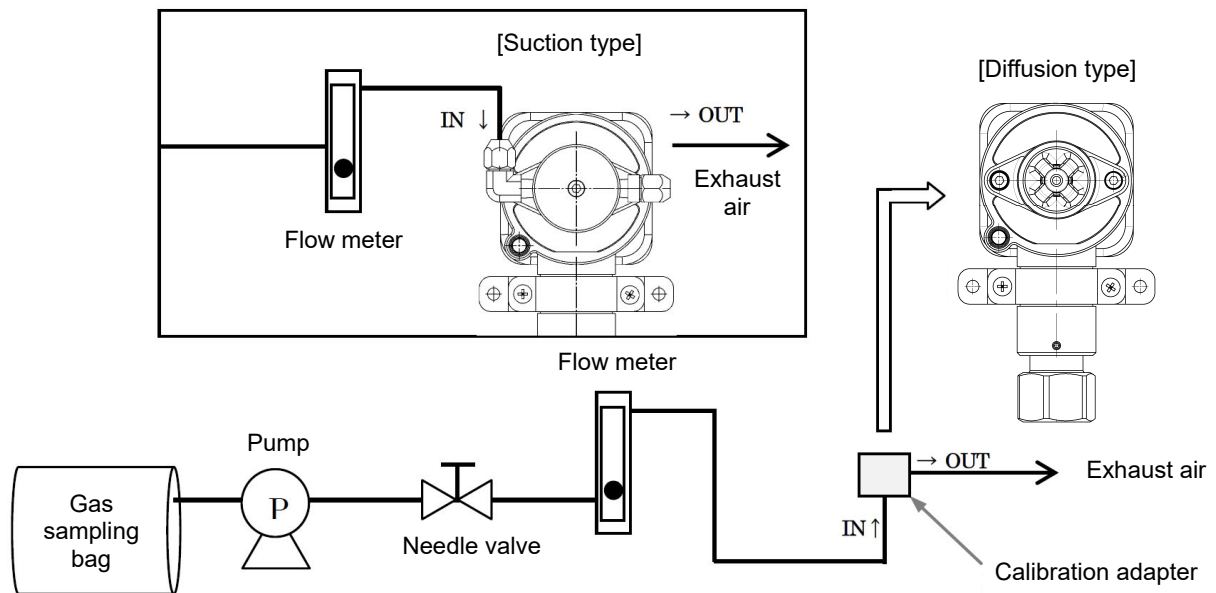

Check and adjustment are performed at the indicator/alarm unit side. See the operating manual of the indicator/alarm unit for details.

(1) Zero adjustment

Adjust the reading to zero at the indicator/alarm unit side under the condition that no gas is present around the detection point.

If a gas is present around the detection point, collect fresh air in a gas sampling bag or the like and release it at the detection point for two minutes or so before starting the zero adjustment.



WARNING

- When the zero adjustment is performed in the atmosphere, check the atmosphere for freshness before beginning the adjustment. If interference gases exist, the calibration cannot be performed properly, thus leading to dangers when the gas leaks.

(2) Span adjustment

Prepare a concentration-known calibration gas (1/2 of FS or 1.6 times the alarm setpoint) in a gas sampling bag to perform the span adjustment.

**CAUTION**

- Before starting the span adjustment, provide the detector with the calibration gas and wait until the reading is stabilized.
- Check that the model of replacement for the gas sensor agrees with the model shown on the sensor model label attached to the detector head.

NOTE

- The span adjustment requires dedicated tools. We recommend the adjustment be performed by RIKEN KEIKI.
-

6-3. Replacement parts

<Sensor Replacement>

Replace the gas sensor according to the following procedure.

- (1) Turn off the indicator/alarm unit power.
- (2) Loosen the two hexagon socket head bolts on the sensor guard of the detector head and remove the sensor guard. (The hexagon socket head bolts on the sensor guard do not drop off even when they are loosened.)
- (3) Pick the top (sintered metal part) of the gas sensor with deteriorated sensitivity with fingers and pull it out. A rubber seal is attached to the sensor guard. (A rubber seal without deformation or damage will be used again. Be careful not to lose it.)
- (4) One of the five pins of the gas sensor is longer than the others. With this long pin positioned farthest from the cable inlet (see figure below), insert it lightly (shallowly) to the socket in the hole of the main unit. Then push the gas sensor to insert it deep in the socket.
- (5) Put the sensor guard over the gas sensor and tighten the two hexagon socket head bolts securely.
- (6) When the replacement of gas sensor is completed, turn on the indicator/alarm unit power to check the gas sensor voltage or current. (See the operating manual of the indicator/alarm unit.)
- (7) Warm up the unit for one hour or so (guide value) after power-on. After that, perform the zero and span adjustments according to "6-2. Calibration method".

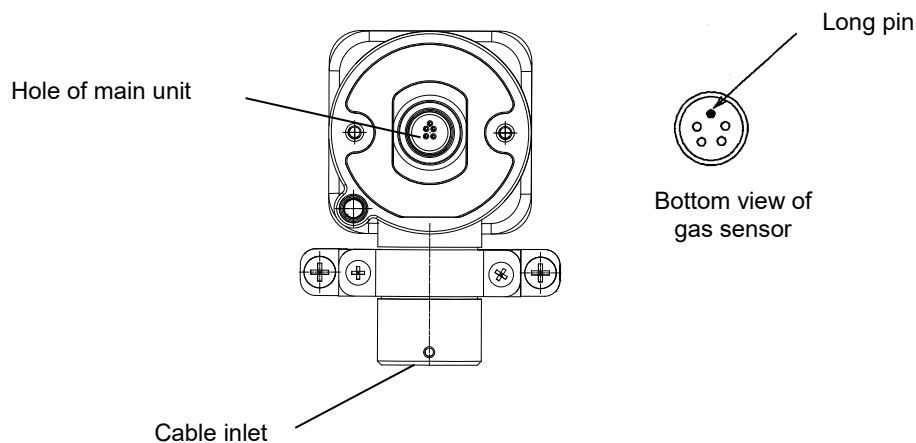

NOTE

- After the sensor is replaced, the voltage, zero and span adjustments must be performed. We recommend the sensor replacement be performed by RIKEN KEIKI.



WARNING

- Do not replace the sensor while it is energized. Doing so may cause ignition, thus leading to dangers.
- Before replacing the sensor, be sure to turn off the sensor power (indicator/alarm unit power) and pump power.

<Replacement of Regular Replacement Parts>

List of recommended regular replacement parts

No.	Item	Maintenance intervals	Replacement intervals (year)	Quantity (pieces/unit)	Part number
1	Rubber seal (sensor)	6 months	3 - 8 years	1	4262 4545 10
2	Suction cap	6 months	3 - 8 years	1	

- * The operation must be checked after replacement by our service engineer. For the stable operation of the detector and safety, ask our service engineer to take care of replacement of the part. Request RIKEN KEIKI for operation check.

NOTE

- The above replacement intervals are recommendation only. The intervals may change depending on the operating conditions. These intervals do not mean the warranty periods either. The result of the regular maintenance may determine when to replace the parts.

7

Storage, Relocation and Disposal

7-1. Procedures to store the detector or leave it for a long time

The detector must be stored under the following environmental conditions.

- In a dark place under the normal temperature and humidity away from direct sunlight
- In a place where gases, solvents or vapors are not present

7-2. Procedures to relocate the detector or use it again

When the detector is relocated, select a new place in accordance with "4-2. Precautions for installation sites" and "4-4. How to install". For information on wiring work, see "4-6. Wiring". The unpowered time must be minimized when the detector is relocated.



CAUTION

When using a relocated or stopped/stored detector again, never fail to perform a calibration. For information on readjustment including a calibration, Please contact RIKEN KEIKI.

7-3. Disposal of products

When the detector is disposed of, it must be treated properly as an industrial waste in accordance with the local regulations.

8

Troubleshooting

The Troubleshooting does not explain the causes of all the malfunctions which occur on the detector. This simply helps to find the causes of malfunctions which frequently occur. If the detector shows a symptom which is not explained in this manual, or still has malfunctions even though remedial actions are taken, please contact RIKEN KEIKI.

<Abnormalities of Readings>

- * Take remedial actions to indicator/alarm unit as well See the operating manual of the indicator/alarm unit for details.

Symptoms	Causes	Actions
<u>The reading rises (drops) and it remains so.</u>	Drifting of sensor output	Perform zero adjustment.
	Presence of interference gas	Disturbances by interference gases, such as solvents, cannot be eliminated completely. For information on actions, such as removal filter, please contact RIKEN KEIKI.
	Slow leak	A very small amount of the gas to be detected may be leaking (slow leak). Because ignoring it may cause dangers, take a remedial measure, i.e., taking actions the same as those for the gas alarm.
	Environmental changes	Perform zero adjustment.
<u>A gas alarm is triggered despite of no gas leak and no other abnormalities at the detection point.</u>	Presence of interference gas	Disturbances by interference gases, such as solvents, cannot be eliminated completely. For information on actions, such as removal filter, please contact RIKEN KEIKI.
	Disturbance by noise	Turn off and restart the detector. If such a symptom is observed frequently, take appropriate measures to eliminate the noise.
	Sudden change in the environment	When the environment (temperature, etc.) changes suddenly, the detector cannot adjust to it and is affected by it. In some cases, the detector triggers an indication alarm. Because the detector cannot be used under sudden and frequent environmental changes, any preventive actions to eliminate them should be taken by the user.
<u>Slow response</u>	Deteriorated sensor sensitivity	Replace the sensor with a new one.
	Clogged dust filter	Replace the dust filter.
	Bent, clogged or leaked suction/exhaust tube	Fix the defective parts.
	Condensation is formed inside the suction tube.	Fix the defective parts.

8 Troubleshooting

<u>Span adjustment impossible</u>	Improper calibration gas concentration	Use the proper calibration gas.
	Deteriorated sensor sensitivity	Replace the sensor with a new one.

9

Product Specifications

9-1. Standard specifications

[Diffusion type]<ATEX/IECEX Specifications>

Model	GD-A80	GD-A80V	GD-A80S	GD-A80N
Detection principle	Catalytic combustion or new ceramic	Semiconductor	Hot-wire semiconductor	Thermal conductivity
Gas to be detected	Combustible gases in the air	Combustible/toxic gases in the air	Combustible/toxic gases in the air	Combustible gases in the air/inert gas
Detection method	Natural diffusion type			
Transmission cable	1.25 or 2.0 mm ²			
	CVV, 4-core or equivalent	CVVS, 3-core or equivalent	CVVS, 4-core or equivalent	
Cable connecting port	Pressure proof packing gland G3/4 [Rubber seal ID] ø12 for mounted, ø13 for attached			
Operating temperatures*	-20 - +53°C (At a constant condition)			
Operating humidities	Below 95% RH (Non-condensing)			
Structure	Wall mounting type, 2B (50A) pipe attachable			
Explosion-proof structure	Flame-proof enclosures			
Explosion-proof class	II2G Ex db IIC T4 Gb (ATEX) Ex db IIC T4 Gb (IECEX)			
External dimensions	Approx. 78 (W) x 163 (H) x 105 (D) mm (Fixing brackets excluded)			
Weight	Approx. 1.0kg			
Paint color	Munsell 7. 5BG5/2			

*The ambient temperature range which maintain a capability of explosion proof of the label on the detector is -40~+53°C. However, the available operating temperature range is -20~+53°C.

[Suction type] <ATEX/IECEX Specifications>

Model	GD-A80D	GD-A80DV	GD-A80DS	GD-A80DN
Detection principle	Catalytic combustion or new ceramic	Semiconductor	Hot-wire semiconductor	Thermal conductivity
Gas to be detected	Combustible gases in the air	Combustible/toxic gases in the air	Combustible/toxic gases in the air	Combustible gases in the air/inert gas
Detection method	Suction type (introduced by an external pump unit)			
Flow rate	0.8 - 2 L/min			
Transmission cable	1.25 or 2.0 mm ²			
	CVV, 4-core or equivalent	CVVS, 3-core or equivalent	CVVS, 4-core or equivalent	
Cable connecting port	Pressure proof packing gland G3/4 [Rubber seal ID] ø12 for mounted, ø13 for attached			
Operating temperatures*	-20 - +53°C (At a constant condition)			
Operating humidities	Below 95% RH (Non-condensing)			
Structure	Wall mounting type, 2B (50A) pipe attachable			
Explosion-proof structure	Flame-proof enclosures			
Explosion-proof class	II2G Ex db IIC T4 Gb (ATEX) Ex db IIC T4 Gb (IECEX)			
External dimensions	Approx. 78 (W) x 163 (H) x 123 (D) mm (Fixing brackets excluded)			
Weight	Approx. 1.0kg			
Paint color	Munsell 7.5BG5/2			

*The ambient temperature range which maintain a capability of explosion proof of the label on the detector is -40~+53°C. However, the available operating temperature range is -20~+53°C.

[Diffusion type]<TIIS Specifications>

Model	GD-A80	GD-A80V	GD-A80S	GD-A80N
Detection principle	Catalytic combustion or new ceramic	Semiconductor	Hot-wire semiconductor	Thermal conductivity
Gas to be detected	Combustible gases in the air	Combustible/toxic gases in the air	Combustible/toxic gases in the air	Combustible gases in the air/inert gas
Detection method	Natural diffusion type			
Transmission cable	1.25 or 2.0 mm ²			
	CVV, 4-core or equivalent	CVVS, 3-core or equivalent	CVVS, 4-core or equivalent	
Cable connecting port	Pressure proof packing gland G3/4 [Rubber seal ID] ø12 for mounted, ø13 for attached			
Operating temperatures*	-20 - +53°C (At a constant condition)			
Operating humidities	Below 95% RH (Non-condensing)			
Structure	Wall mounting type, 2B (50A) pipe attachable			
Explosion-proof structure	Flame-proof enclosures			
Explosion-proof class	Ex d IIC T4 (TIIS<Japan>)			
External dimensions	Approx. 78 (W) x 163 (H) x 105 (D) mm (Fixing brackets excluded)			
Weight	Approx. 1.0kg			
Paint color	Munsell 7. 5BG5/2			

*The ambient temperature range which maintain a capability of explosion proof of the label on the detector is -40~+53°C. However, the available operating temperature range is -20~+53°C.

[Suction type] <TIIS Specifications>

Model	GD-A80D	GD-A80DV	GD-A80DS	GD-A80DN
Detection principle	Catalytic combustion or new ceramic	Semiconductor	Hot-wire semiconductor	Thermal conductivity
Gas to be detected	Combustible gases in the air	Combustible/toxic gases in the air	Combustible/toxic gases in the air	Combustible gases in the air/inert gas
Detection method	Suction type (introduced by an external pump unit)			
Flow rate	0.8 - 2 L/min			
Transmission cable	1.25 or 2.0 mm ²			
	CVV, 4-core or equivalent	CVVS, 3-core or equivalent	CVVS, 4-core or equivalent	
Cable connecting port	Pressure proof packing gland G3/4 [Rubber seal ID] ø12 for mounted, ø13 for attached			
Operating temperatures*	-20 - +53°C (At a constant condition)			
Operating humidities	Below 95% RH (Non-condensing)			
Structure	Wall mounting type, 2B (50A) pipe attachable			
Explosion-proof structure	Flame-proof enclosures			
Explosion-proof class	Ex d IIC T4 (TIIS<Japan>)			
External dimensions	Approx. 78 (W) x 163 (H) x 123 (D) mm (Fixing brackets excluded)			
Weight	Approx. 1.0kg			
Paint color	Munsell 7.5BG5/2			

*The ambient temperature range which maintain a capability of explosion proof of the label on the detector is -40~+53°C. However, the available operating temperature range is -20~+53°C.

9-2. Detection principle

<Catalytic Combustion>

When a combustible gas burns on the surface of an oxidation catalyst, the catalytic combustion type sensor considers resultant combustion heat as temperature and resistance changes in the platinum wire coil, and measures their gas concentrations.

This sensor detects any combustible gases. The detection range is from zero to the lower explosive limit. When a highly-concentrated gas over the lower explosive limit comes into contact with the sensor, it may cause a break.

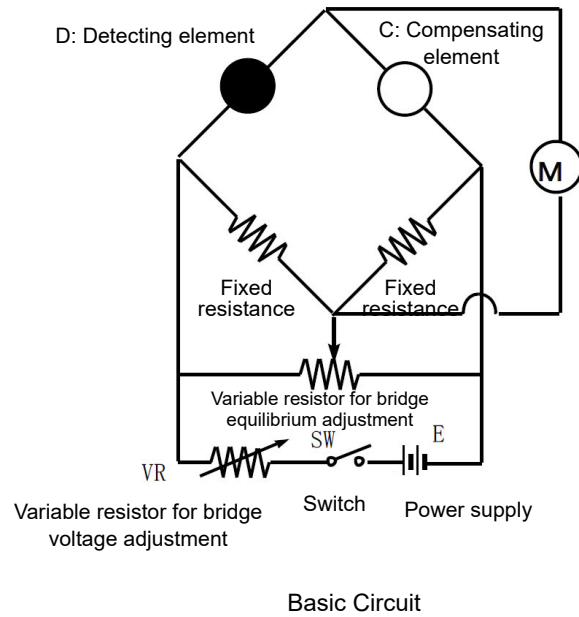
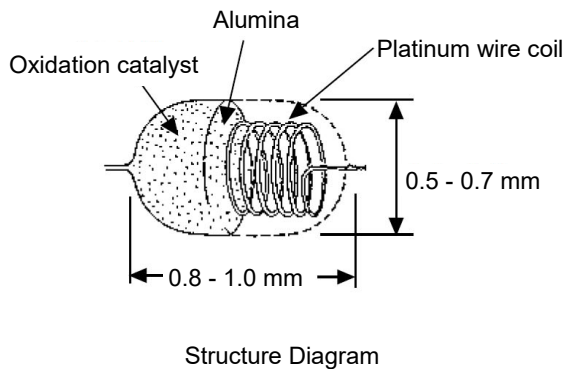

<New Ceramic Type>

When a combustible gas burns on the surface of a highly active new ceramic oxidation catalyst in catalytic combustion, the new ceramic-type sensor measures resultant temperature changes by measuring the resistance changes in the heat-resistant alloy wire coil.

The sensor consists of two elements: A detecting element having a heat-resistant alloy wire coil with an ultrafine particle (new ceramic) oxidation catalyst sintered on it together with a carrier and a temperature-compensating element with a mixture of gas-inert alumina and glass sintered on it.

When a combustible gas comes into contact with the surface of the detecting element with new ceramic oxidation catalyst sintered on it, the gas burns, causing the temperature to rise. In accordance with this temperature change, there occurs a change in the resistance of a heat-resistant alloy wire coil that constitutes the element. These resistance values are approximately proportional to gas concentrations. From the changes in the resistance values, potential differences are obtained using a bridge circuit and displayed as gas concentrations on the meter.

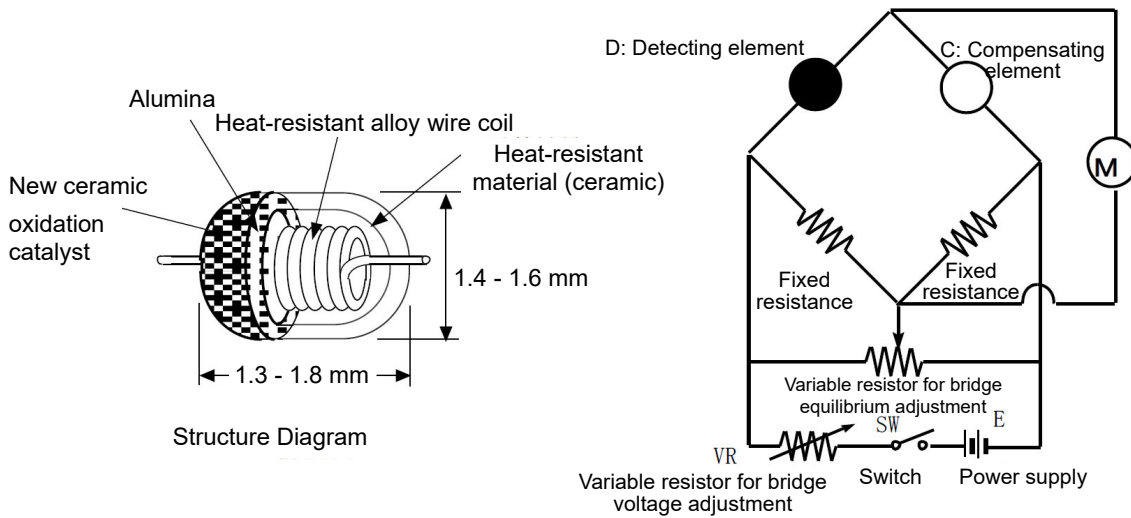

Basic Circuit

<Semiconductor Type>

The semiconductor type sensor detects a change in resistance that occurs when a metal oxide semiconductor contacts a gas as gas concentration. This is a general-purpose gas detection sensor that can promptly react to various kinds of gases such as toxic and combustible gases.

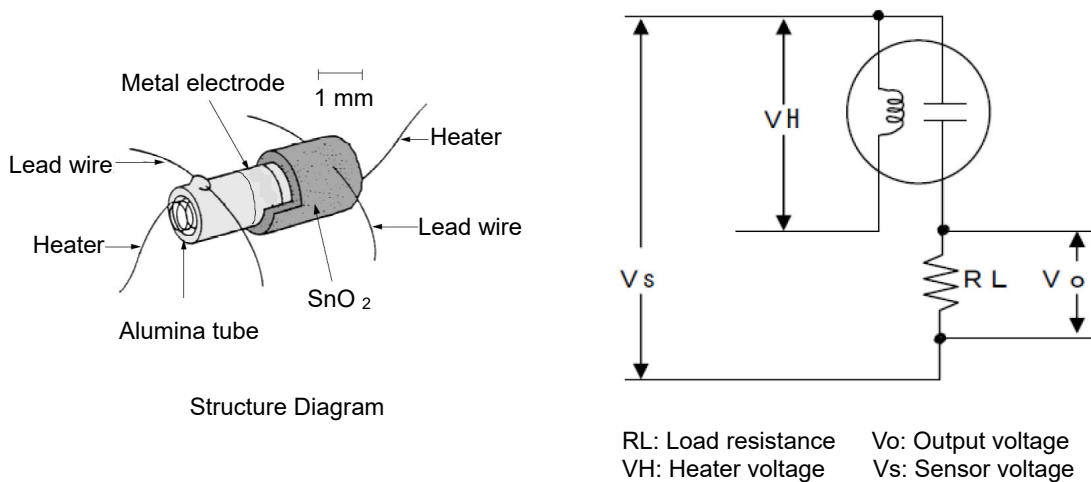

RL: Load resistance Vo: Output voltage
 VH: Heater voltage Vs: Sensor voltage

Basic Circuit

<Hot-wire Semiconductor>

The hot-wire semiconductor type sensor detects a change in resistance of the platinum wire coil integrated in a metal oxide semiconductor whose resistance value changes by contact with a gas as gas concentration. This is a highly sensitive gas detection sensor suitable for low concentrations.

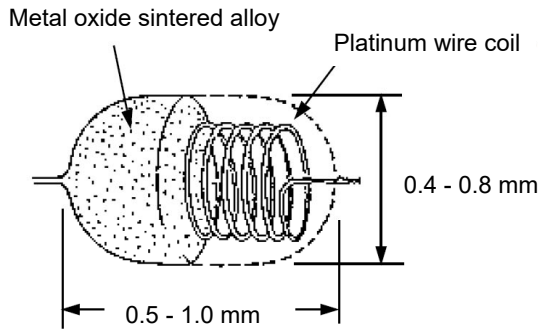

Structure Diagram

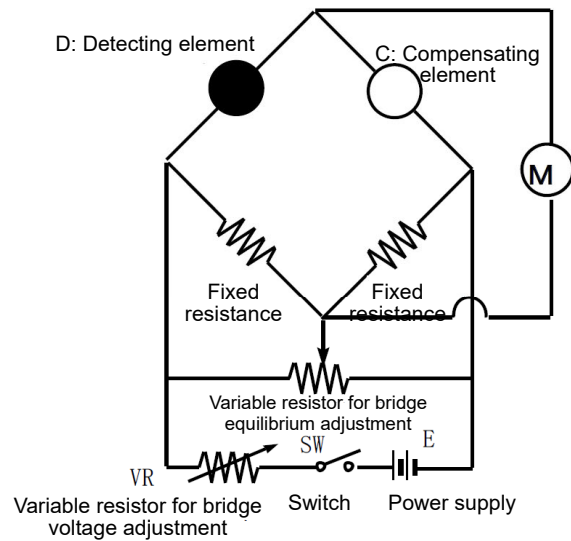

Basic Circuit

<Thermal Conductivity>

The thermal conductivity type sensor detects a difference in thermal conductivity of a gas as gas concentration. There are two types of detecting elements: The one with a mixture of gas-inert alumina and glass sintered on a platinum wire coil, etc. and the other one coating a platinum wire coil, etc. with inert metal or the like. The compensating element is sealed to avoid contact with a gas.

When the detecting element heated to a temperature of 200 to 500°C by the platinum wire coil contacts the gas to be detected, the heat radiation status changes due to the gas-specific thermal conductivity, causing a change in the detecting element temperature.

In accordance with this temperature change, there occurs a change in the resistance of the platinum wire coil that constitutes the element. The changes in the resistance are approximately proportional to gas concentrations. The amount of change in the resistance is obtained as a voltage value using a bridge circuit and it is displayed as a gas concentration.

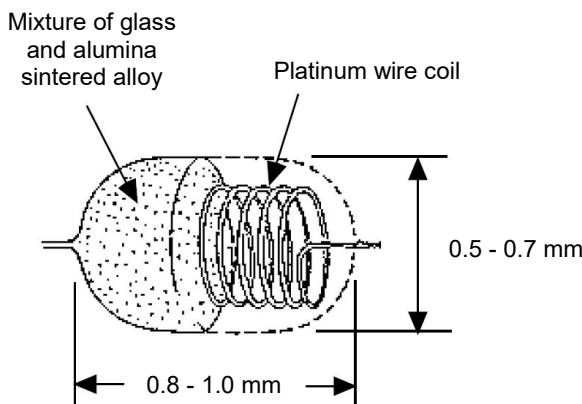

Structure Diagram

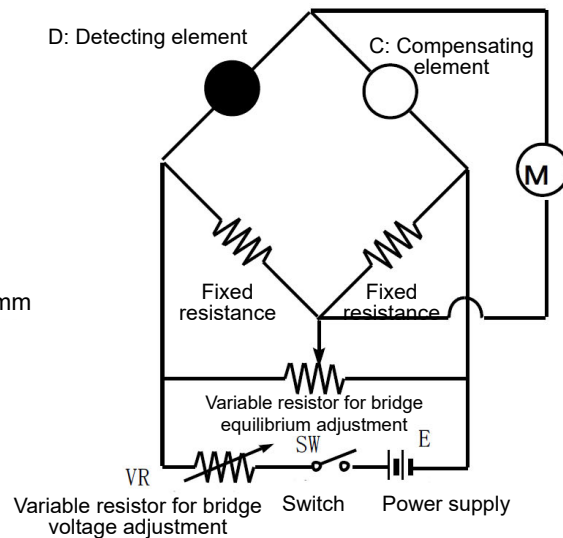

Basic Circuit

10

Definition of Terms

Catalytic combustion type	This is a principle of the sensor installed in GD-A80(D). See "9-2. Detection principle" for details.
New ceramic	This is a principle of the sensor installed in GD-A80(D). See "9-2. Detection principle" for details.
Semiconductor	This is a principle of the sensor installed in GD-A80(D)V. See "9-2. Detection principle" for details.
Hot-wire semiconductor	This is a principle of the sensor installed in GD-A80(D)S. See "9-2. Detection principle" for details.
Thermal conductivity	This is a principle of the sensor installed in GD-A80(D)N. See "9-2. Detection principle" for details.
Initial clear	Output from the detector head fluctuates for a while after turning on the power. This is a function to prevent triggering alarm during that time.
Full scale	Maximum value of the detection range.
% LEL	A unit that assumes the lower explosive limit of the combustible gas to be detected as 100.
ppm	A concentration unit that means part per million of the combustible gas to be detected.
Calibration	Adjusts the readings to the calibration gas concentration value by using the calibration gas.

Declaration of Conformity

We, **RIKEN KEIKI Co., Ltd.**

2-7-6, Azusawa, Itabashi-ku,
Tokyo, 174-8744, Japan

declare in our sole responsibility that the following
product conforms to all the relevant provisions.

Product Name	:	Gas Detector
Model Name	:	GD-A80, GD-A80D, GD-A80V, GD-A80DV, GD-A80S, GD-A80DS, GD-A80N, GD-A80DN, GD-A80-70, GD-A80D-70
Council Directives	:	EMC : 2014/30/EU
		ATEX : 2014/34/EU
Applicable Standards	:	RoHS : 2011/65/EU
		EMC : EN 50270:2015 (Type2)
		ATEX : EN 60079-0:2018 EN 60079-1:2014
		RoHS : EN 50581(2012)
Name and address of the ATEX Notified Body	:	DNV Nemko Presafe AS (NB 2460) Gaustadalléen 30 0373 Oslo Country : Norway
Number of the EU type examination certificate	:	PRESAFE 20 ATEX 64381X
Name and address of the ATEX Auditing Organization	:	DNV GL Presafe AS (NB 2460) Veritasveien 3 1363 Høvik Norway

The Marking of the equipment or protective system shall include the
following : II 2G Ex db II C T4 Gb

Year to begin affixing CE Marking : 2017

Place: TOKYO, Japan

Signature: 
Full name: Toshiyuki Takakura

Date: Aug. 1, 2020

Title: Director, Quality control center