

GADMS Lite Simple Network Gas Monitoring System

Model: GADMS-L01

Operating Manual

RIKEN KEIKI Co., Ltd.

2-7-6 Azusawa, Itabashi-ku, Tokyo, 174-8744, Japan

Website: <https://www.rikenkeiki.co.jp/>

Contents

Contents	1
1 About This Document.....	3
1-1 Introduction.....	3
1-2 DANGER, WARNING, CAUTION, and NOTE	4
2 Important Safety Information.....	5
3 Product Configuration	7
3-1 Product components.....	7
3-2 Exterior drawings.....	8
3-3 Part names and functions.....	8
4 Usage Instructions	8
4-1 Usage note	8
4-2 Precautions regarding installation location	9
4-3 System design precautions	10
4-4 Installation procedure	10
5 Device Connection	11
5-1 Terminal plate specifications	11
5-2 Connection example.....	14
6 Individual Operations	15
6-1 Gas alarm pattern.....	15
6-2 Fault alarm pattern	19
7 Communication Settings	20
7-1 Using the system with a local connection	20
7-1-1 Altering the PC IP address	21
7-1-2 Setting the gas detector IP addresses	23
7-1-3 Accessing the system with a local connection	25
7-2 Using the system connected to the Internet.....	26
7-2-1 Connecting the Ewon Flexy 205 (GADMS Lite) to the Internet (via router, etc.)	26
7-2-2 Creating a Talk2M account.....	27
7-2-3 Registering the Ewon to the account created	30
7-2-4 Loading the setup file to the Ewon Flexy 205	34
7-2-5 Accessing the system by connecting to the Internet.....	35
7-3 Configuring various settings.....	37
7-3-1 Setting email addresses	38
7-3-2 Setting the email header.....	38
7-3-3 Altering the GADMS-L01 IP address.....	38

7-3-4	Setting the time (Only when using a local connection)	39
7-3-5	Changing the Ewon Flexy 205 (GADMS Lite) login password	39
7-3-6	Disabling auto-refresh	40
8	Operations and Functions	41
8-1	System screen configuration	41
8-2	Chart (list screen)	42
8-3	Details (details screen)	45
8-4	Summary & History (alarm summary and history)	49
8-5	Settings (setting information screen)	51
8-6	Email function	53
8-6-1	Example email content	53
8-7	KPI (standard M2WEB function)	56
9	Storage, Relocation, and Disposal	57
9-1	Storage	57
9-2	Relocation	57
9-3	Disposal	57
10	Troubleshooting	58
11	List of Specifications	60
12	Terminology	60

1 About This Document

1-1 Introduction

Thank you for purchasing the GADMS-L01 (“the product” hereinafter).

This operating manual describes the operating procedures and specifications for the GADMS-L01.

Make sure you have read and fully understood the contents of this manual before use.

GADMS Lite is a simple network gas monitoring system. It consists of an Ewon Flexy 205 system device on which GADMS Lite software is installed. It supports the Riken Keiki GD-70D-EA gas detector. Please also read the operating manuals for the associated devices.

Keep this operating manual on hand to allow ready reference during use. The contents of this manual are subject to change without notice to allow product improvements.

Any duplication or reproduction of this manual without permission is prohibited, whether in whole or in part. All images included here are provided for reference purposes. Depending on the setup, they may depart from the actual configuration of the equipment.

Riken Keiki accepts no liability for accidents or damage resulting from use of programs of devices communicating with the product, whether within or outside the warranty period.

Review the warranty policy indicated on the warranty.

The following sections are derived from figures or descriptions in the Ewon Flexy 205 Operating Manual.

3-2 Exterior drawings

3-3 Part names and functions

4-4 Installation procedure

5-1 Terminal plate specifications

7-2-4 Loading the setup file to the Ewon Flexy 205

Ewon Flexy 205 Operating Manual

©HMS Industrial Networks

<https://hmsnetworks.blob.core.windows.net/www/docs/librariesprovider10/downloads-monitored/manuals/installation-guides/ig-0028-00-ewon-flexy-base-unit-205.pdf>

1-2 DANGER, WARNING, CAUTION, and NOTE

This operating manual uses the following categories to indicate potential damage/hazards if the user disregards the information provided and handles the product incorrectly:



This indicates situations in which improper handling may result in fatal or serious injury or significant property damage.



This indicates situations in which improper handling may result in serious injury or significant property damage.



This indicates situations in which improper handling may result in minor injury or minor property damage.

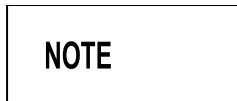

Additionally, usage recommendations are indicated as follows: This indicates items that will be helpful to know when using the product.

2 Important Safety Information



WARNING

- **Power supply**

Before turning on the power for the product, be sure to confirm that the power source meets the specified voltage requirements. Avoid using unstable power sources; doing so may lead to malfunctions.

- **Operating in the presence of gases**

Do not operate this product in locations where combustible or explosive gases or vapor is present. Operating this product in such environments is extremely hazardous.

- **Action if a gas alarm occurs**

A gas alarm indicates an extreme hazard. The user must take appropriate action based on the situation.



CAUTION

- **Do not use devices that generate strong magnetic fields near the product.**

Use near strong magnetic fields may cause unstable operation.

- **Do not disassemble or modify the product or alter the settings unnecessarily.**

Altering the settings unnecessarily without a proper understanding of the details may prevent the alarm from operating correctly. Use the product correctly in accordance with this operating manual.

Never attempt to disassemble or modify the product. Doing so will void product performance guarantees.

- **Removing the FLX3402 (I/O extension card)**

Do not remove the FLX3402 (I/O extension card) while the Ewon Flexy 205 is turned on.

Likewise, do not turn the power on while the card is removed. This may cause problems with the system program and prevent correct operation. Be sure to turn the power off before removing the card.

- **Monitoring from the browser alone is not recommended.**

Email abnormality alerts may not be sent and monitoring may be interrupted if cables are damaged or communication problems arise when an alarm occurs. To ensure safety, we recommend using the contact outputs and incorporating alarms such as rotating lights and buzzers into the system.

- **Contact outputs**

Use the contact outputs for external alarm lamps and buzzers. Riken Keiki rejects liability for all malfunctions in cases in which the contact outputs are used for other controls.

3 Product Configuration

3-1 Product components

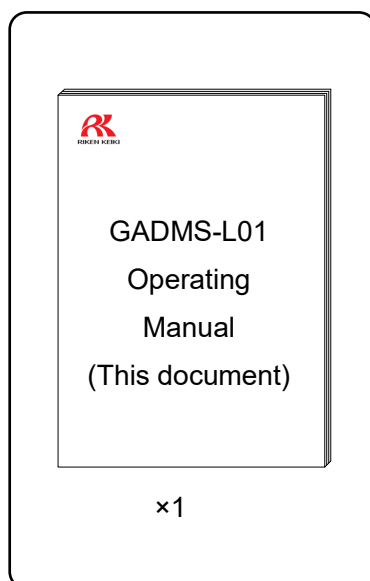
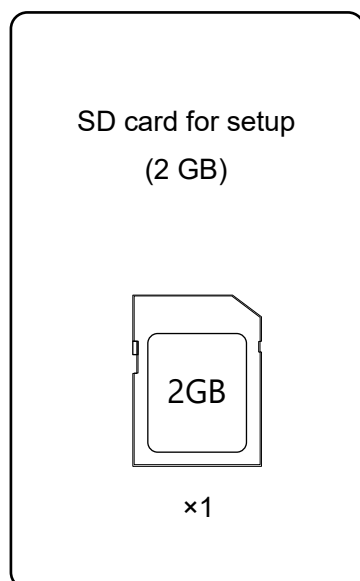
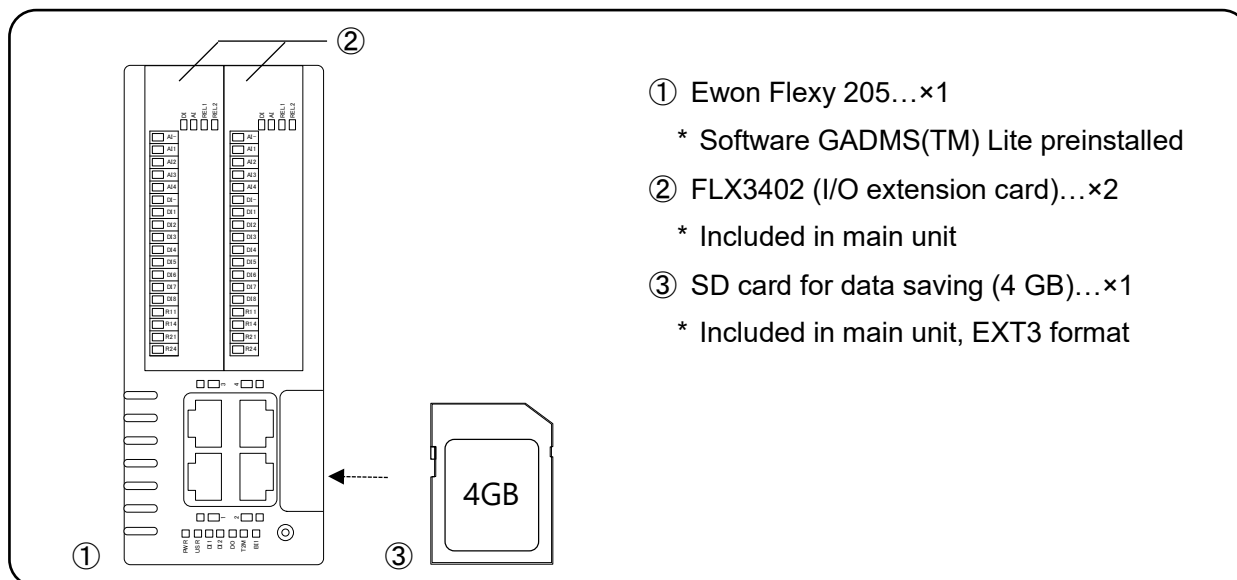

3-2 Exterior drawings

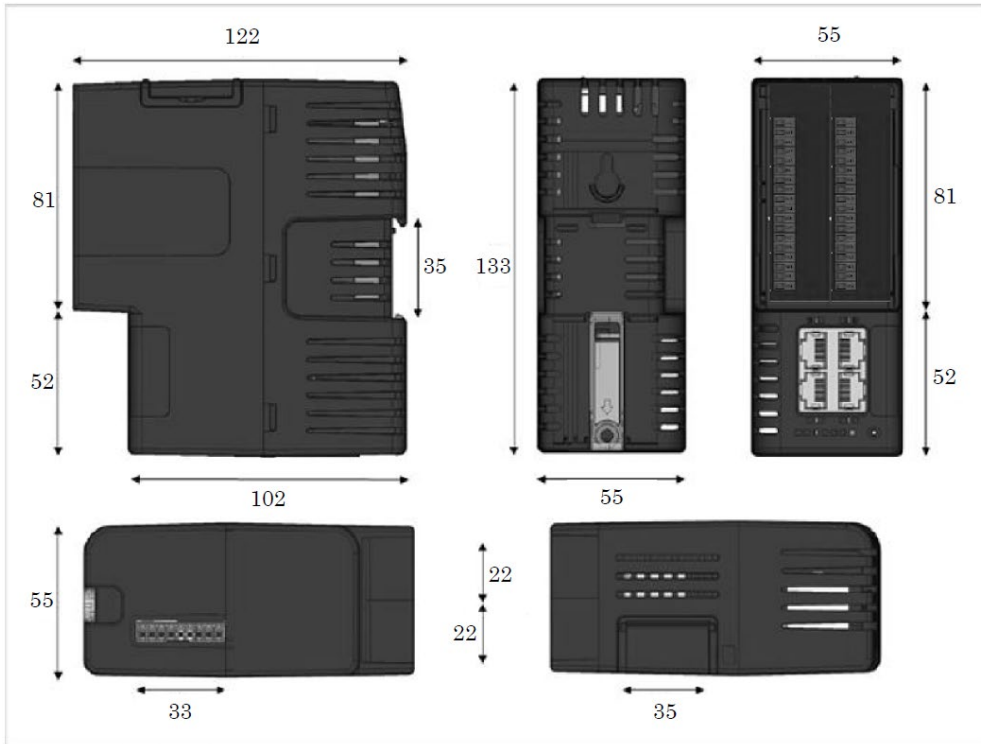

3-3 Part names and functions

Please refer to the Ewon Flexy 205 Specifications.

4 Usage Instructions

4-1 Usage note

The usage precautions apply to both users who have previously used the product and first-time users. Failure to comply with these precautions may result in product failure or improper functioning.



CAUTION

Use the product as soon as possible after delivery.

4-2 Precautions regarding installation location



CAUTION

The product is a precision device. The specified performance may not be achieved depending on the location (environment) in which the product is installed. Check the installation location environment. The end user must implement appropriate remedial measures where necessary.

- **Do not install the product in locations subject to vibration or impact.**

The product contains precision electronic components. Install the product in a stable location not exposed to vibration, impact, or risk of falling.

- **Do not install in locations exposed to water, oil, or chemicals.**

Avoid installing the product in locations exposed to splashing liquids such as water, oil, and chemicals.

- **Do not install in locations where temperatures can fall below -25 °C or exceed 60 °C.**

The operating temperature range for the product is between -25 °C and 60 °C. Install in a stable location within the specified operating temperature range and free of sudden temperature fluctuations.

- **Do not install in locations exposed to direct sunlight or sudden temperature fluctuations.**

Avoid locations exposed to direct sunlight or radiant heat (infrared radiation from high-temperature bodies) and locations that may subject the product to sudden temperature fluctuations.

Condensation may form inside the product, or the product may be unable to adjust to sudden temperature fluctuations.

4-3 System design precautions



CAUTION

Unstable power sources or noise may result in malfunctions or false alarms.

- **Use a stable power source.**

Note that the product's external output and alarm contacts may activate while the system stabilizes at power-on or in the event of an instantaneous power failure. In such cases, either use a UPS (uninterruptible power system) or take appropriate measures on the side receiving the power.

Supply this product with a power source that meets the following requirements:

Power supply	12 - 24 V DC \pm 20 %
Power consumption	72 W Max.

- **Use the alarm contacts correctly.**

The alarm contacts on this product are designed to transmit signals that activate external buzzers and alarm indicators. Do not use for control purposes—for example, do not use to control shutoff valves.



CAUTION

A de-energized b contact (break contact) may cause a momentary open operation due to an external force or other physical impact.

If a b contact is used as an alarm contact, implement measures to account for such momentary operations—for example, adding a delay operation (of approximately one second) to the signal on the b contact receiving side.

4-4 Installation procedure

The product is designed to be mounted on a DIN rail or wall.

For more information, refer to the Ewon Flexy 205 Specifications.

5 Device Connection

5-1 Terminal plate specifications

LAN/WAN Ethernet ports

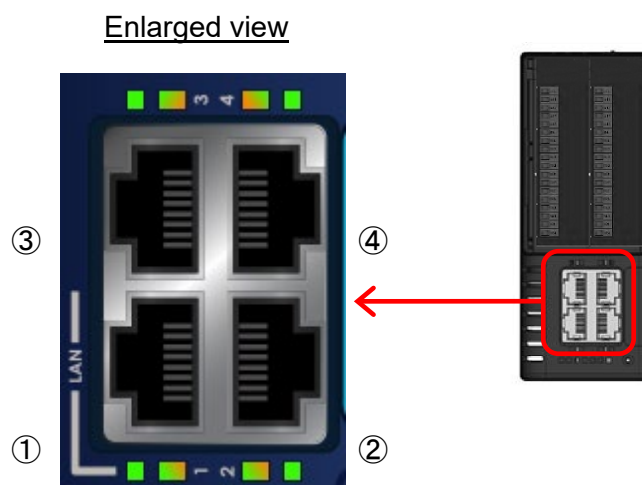

Ethernet connector: RJ45

No.	Port No.	Description	Remarks
①	1	Local area network communication port (LAN port 1)	Used for communication with gas detectors and a monitoring PC
②	2	Local area network communication port (LAN port 2)	
③	3	Local area network communication port (LAN port 3)	
④	4	Wide area network communication port (WAN port)	Used for configurations that require an Internet connection

Main connector

Enlarged view

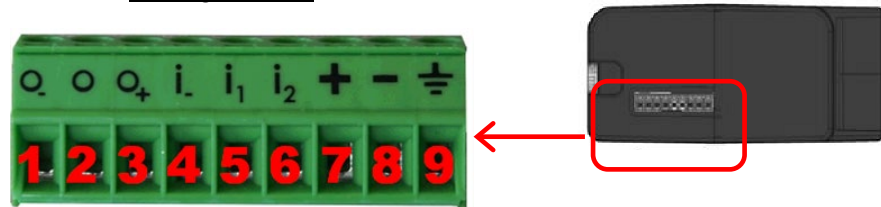

No.	Terminal symbol	Signal
1	O-	Heartbeat signal power supply (12 V - 24 V DC negative)
2	O	Heartbeat signal output
3	O+	Heartbeat signal power supply (12 V - 24 V DC positive)
4	i-	Buzzer stop signal power supply (12 V - 30 V DC negative)
5	i1	Buzzer stop signal input
6	i2	Unused terminal
7	+	Feed power supply (12 V - 24 V DC positive)
8	-	Feed power supply (12 V - 24 V DC negative)
9	Ground	Ground

I/O connectors

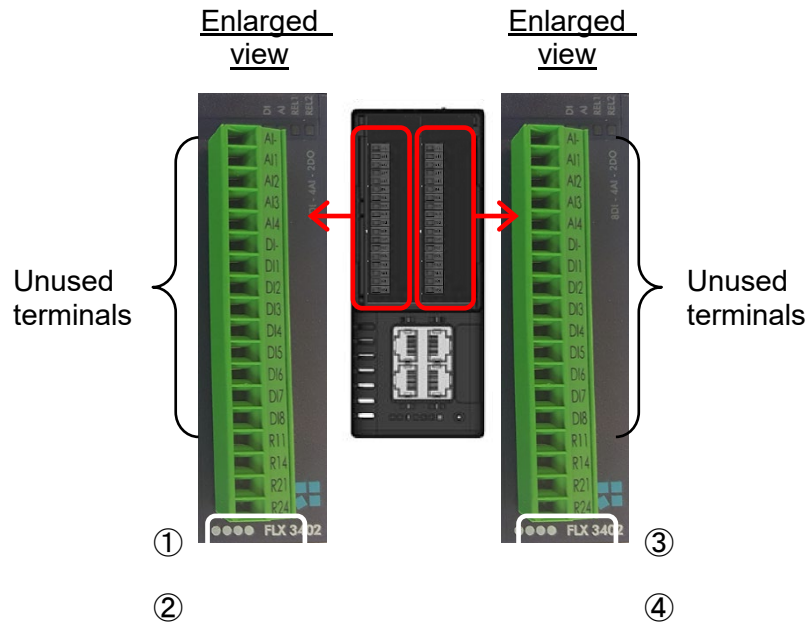

No.	Terminal symbol	Signal
①	R11	ALM2 alarm contact output (N.O.)
	R14	
②	R21	ALM1 alarm contact output (N.O.)
	R24	

No.	Terminal symbol	Signal
③	R11	Fault alarm contact output (N.O.)
	R14	
④	R21	Buzzer contact output (N.O.)
	R24	

5-2 Connection example

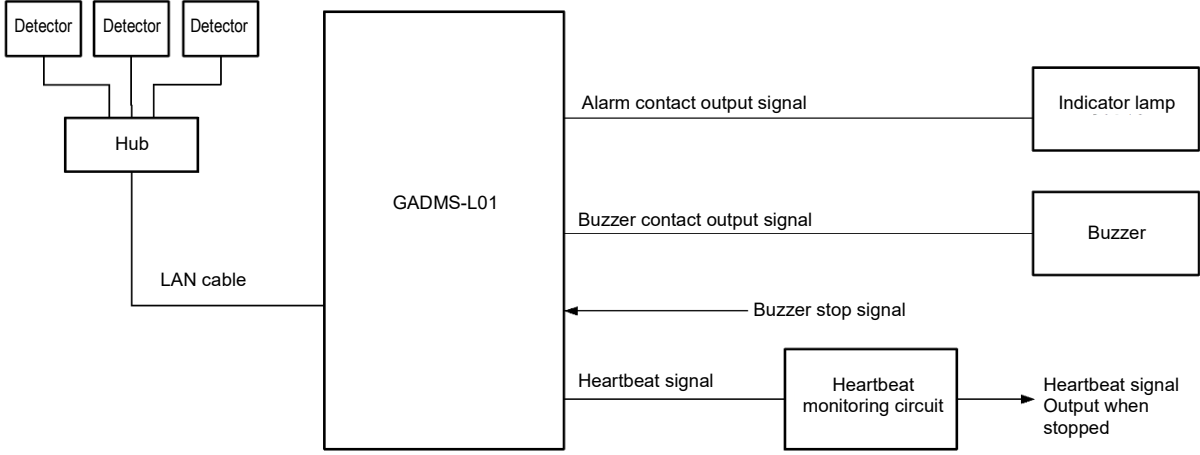

6 Individual Operations

6-1 Gas alarm pattern

Gas alarm: Triggered if the concentration of the detected gas reaches or exceeds the alarm setpoint

《Auto reset or self-latching operation》

NOTE

- The gas alarm operation will depend on the operation of the gas detector(s) connected to the product.
 - The gas detector alarm setpoints (first and second alarms) and alarm pattern (auto reset or self-latching) are factory-set before shipment.
 - An alarm delay (standard setting: two seconds) is set for gas detectors to prevent accidental alarm activation.
-

<Indications>

- **Gas concentration display**

Displays the current gas concentration.

- **Alarm status display (ALM1: Yellow), (ALM2: Red)**

The alarms are two-step alarms.

The alarm lamps light up when the corresponding alarm setpoint is reached or exceeded.

The alarm status display differs for Chart (list screen) and Details (details screen).

Chart (list screen)

When a first alarm occurs, the title information ALM1 and the corresponding gas detector information light up in yellow.

When a second alarm occurs, the title information ALM2 and the corresponding gas detector information light up in red.

Details (details screen)

When a first alarm occurs, the title information ALM1 and [Gas alarm (ALM1)] light up in yellow.

When a second alarm occurs, the title information ALM2 and [Gas alarm (ALM1)] light up in yellow, and [Gas alarm (ALM2)] lights up in red.

<When gas detector alarm pattern is auto reset>

When the gas detector is set to auto reset, the contact is triggered if the gas concentration reaches or exceeds the alarm setpoint. The contact operation is automatically reset when the gas concentration falls below the alarm setpoint.

When the buzzer contact is activated, it can be deactivated by buzzer stop.

Alarm pattern (H-HH)

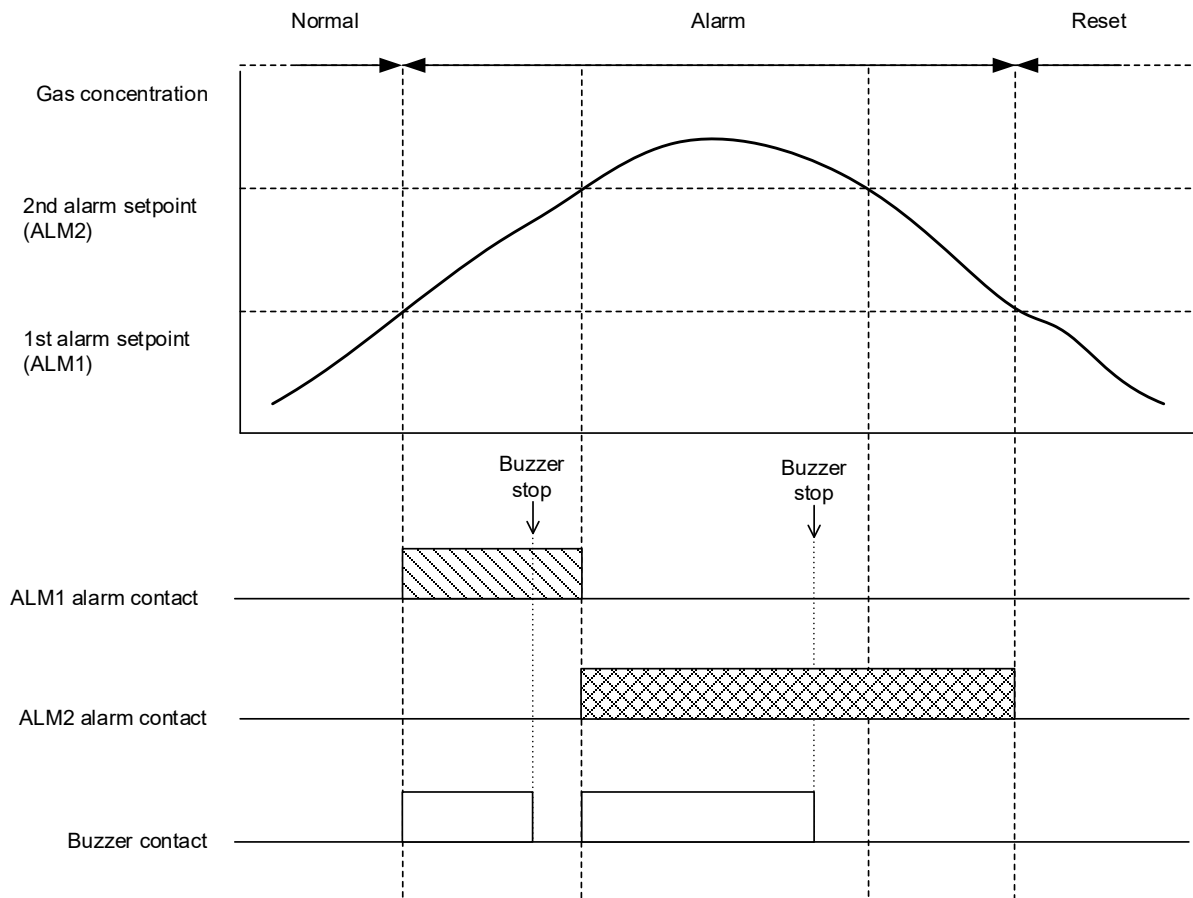

<When gas detector alarm pattern is self-latching>

When the gas detector is set to self-latching, the alarm contact is triggered if the gas concentration reaches or exceeds the alarm setpoint.

The contact operation is reset when the gas concentration falls below the alarm setpoint and the gas detector is reset.

When the buzzer contact is activated, it can be deactivated by pressing the buzzer stop button.

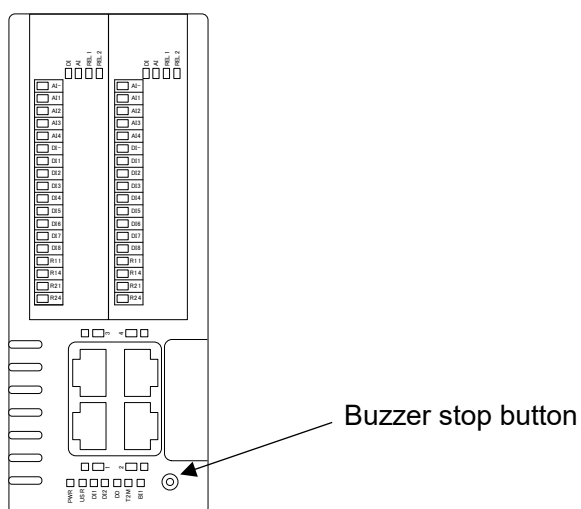

NOTE

For more information on how to reset gas detectors, refer to the operating manual for the gas detector(s) in use.

Alarm pattern (H-HH)

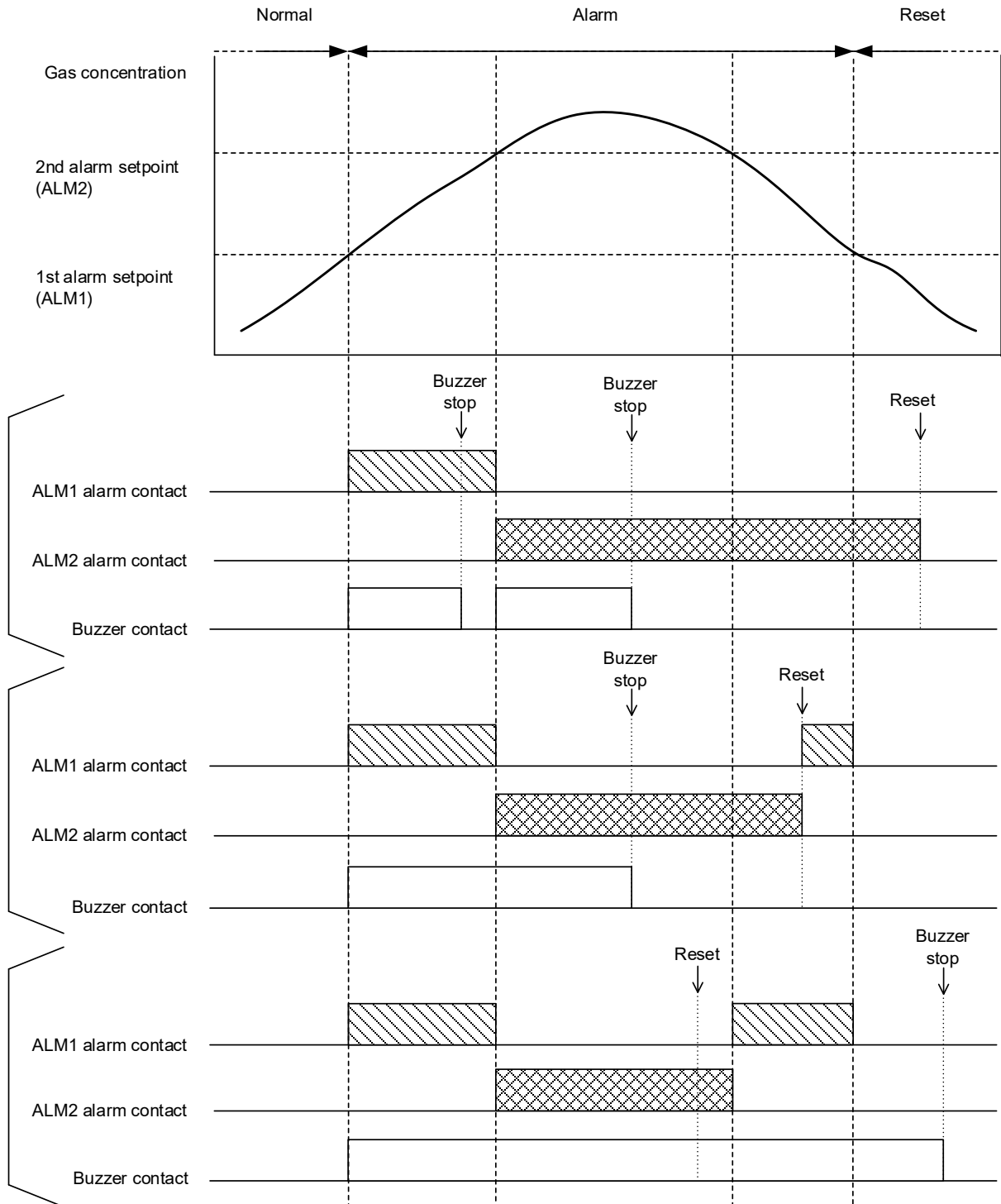

6-2 Fault alarm pattern

A fault alarm is displayed and the fault alarm contacts are triggered if a fault occurs with a gas detector.

Determine the cause and take appropriate action.

After the gas detector has successfully recovered from the fault, it restarts with the process normally performed right after it is turned on (initialization).

Depending on the type of fault alarm, the indications given will be as follows:



- If the problem lies with the gas detector and the fault occurs repeatedly, contact your agent or Riken Keiki immediately.
-

<Indications>

• **Detector fault**

When a detector fault occurs, the title information FAULT and [Detector fault] for the corresponding gas detector light up in orange.

• **Sensor fault**

When a sensor fault occurs, the title information FAULT and [Sensor fault] for the corresponding gas detector light up in orange.

• **Flow rate abnormality**

When a flow rate abnormality occurs, the title information FAULT and [Flow fault] for the corresponding gas detector light up in orange.

7 Communication Settings

7-1 Using the system with a local connection

IP addresses must be set for the product, the PC used to view and operate the system screen, and the individual gas detectors before using the system. The following figure shows an example in which gas detector information is displayed at position [GD_001] on the Chart (list screen). The IP addresses shown are examples when the product IP address is left at the default value. The following description is based on this example.

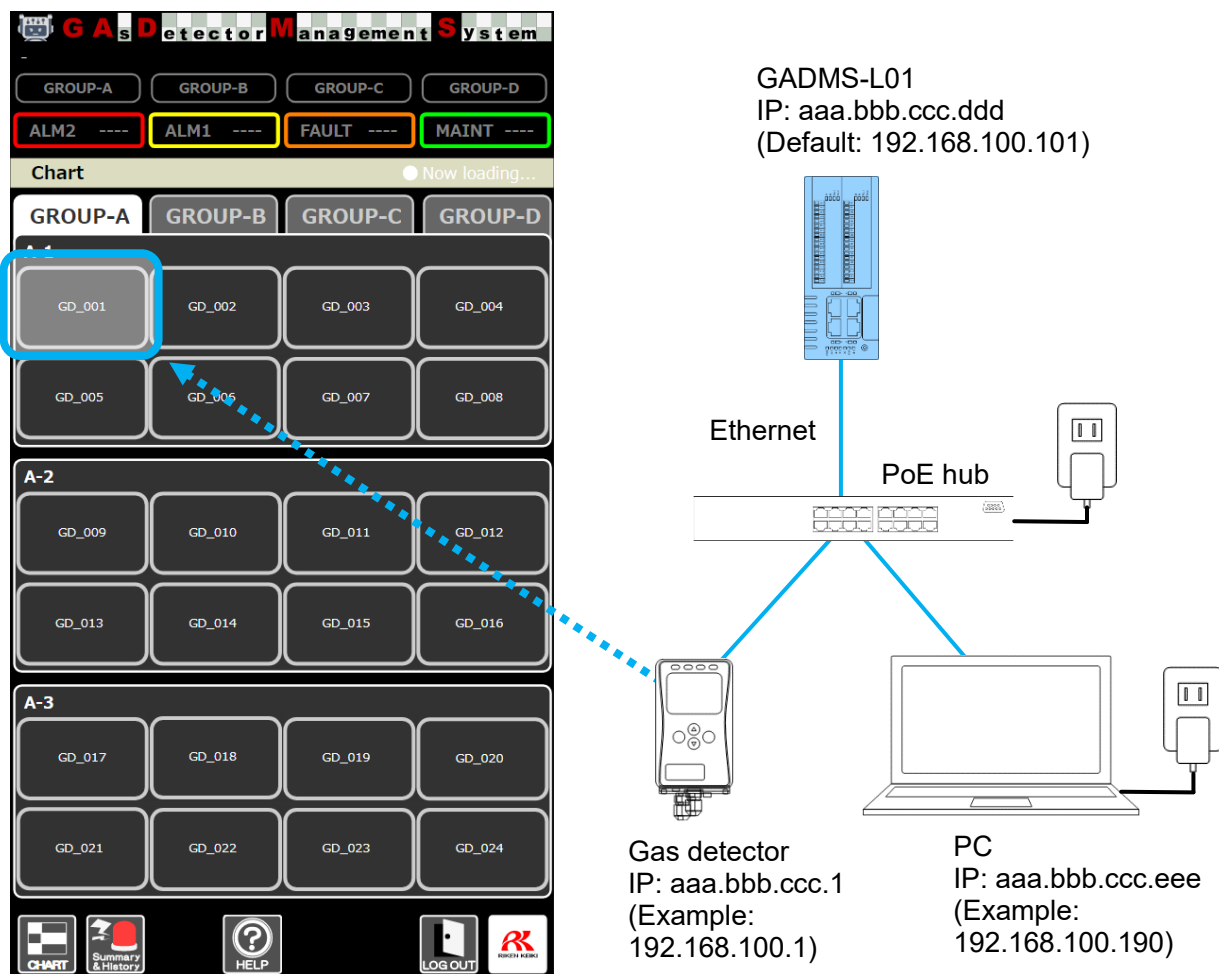

NOTE

- Choose the IP address settings aaa.bbb.ccc based on your particular system setup. ddd should be set to a value in the range 97 to 254, and should differ from the value for eee. For more information on setting procedures, refer to '[7-3 Configuring various settings p. 37](#)'.
- For more information on the system screen layout, refer to '[8 Operations and Functions p. 41](#)'.

7-1-1 Altering the PC IP address

Alter the IP address for the PC.

Example: Altering the IP address setting to 192.168.100.190 using Windows 10

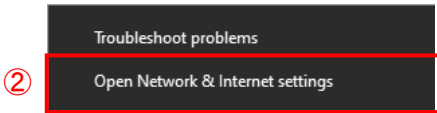

Right-click the ① icon on the task bar to display the menu.

Click ② [Open Network & Internet settings].

Click ③ [Network and Sharing Center].

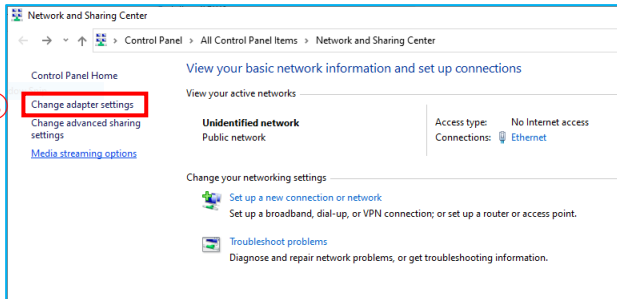
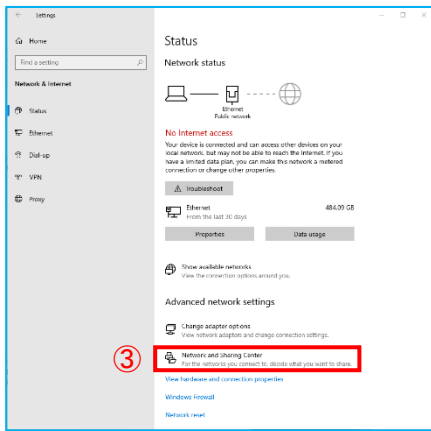

Click ④ [Change adapter settings].

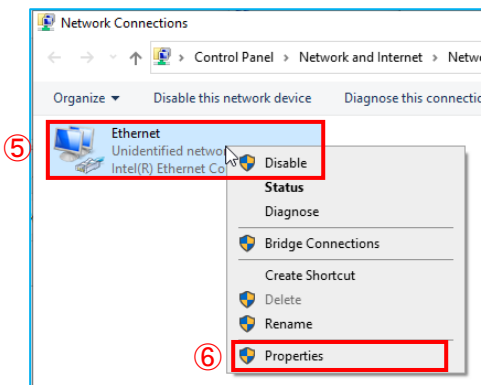

Right-click ⑤ [Ethernet] to display the menu.

Click ⑥ [Properties].

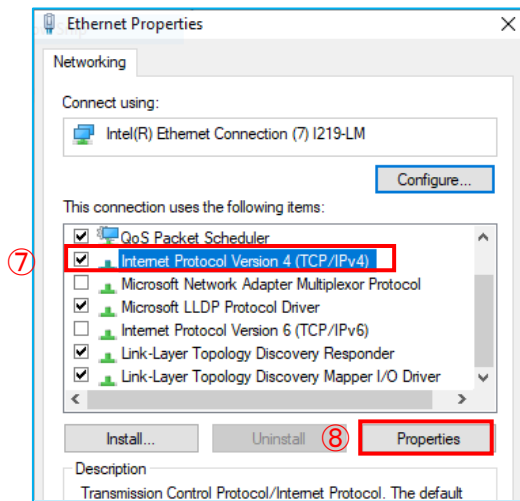

Select ⑦ [Internet Protocol Version 4].
Click ⑧ [Properties].

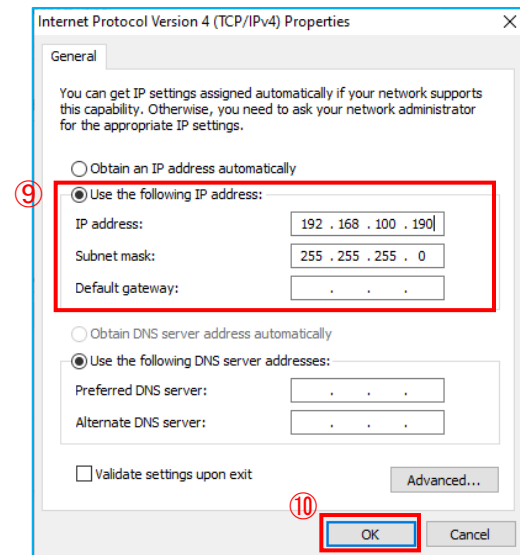

Select the radio button for ⑨ [Use the following IP address], then enter the IP address.

(The example IP address illustrated is set to 192.168.100.190.)

Set the subnet mask to 255.255.255.0.

Click ⑩ [OK].

The PC IP address has now been set.

NOTE

- The illustrations and descriptions provided here are examples. The setting procedure will differ depending on the operating system version and type.
- Administrator rights are required to set the IP address.

If you are unable to change the settings, check with the section in charge of your PC.

7-1-2 Setting the gas detector IP addresses

Shown below is the correspondence between the Chart (list screen) layout and IP addresses. Set the IP addresses for each detector at the location where they are to be displayed. Set as described in the communication function manual for the gas detectors to be used.



Setting example: Using with the product IP address left at the default value

Setting to 192.168.100.1 displays information in the GROUP-A, A-1, GD_001 position.

Setting to 192.168.100.89 displays information in the GROUP-D, D-3, GD_089 position.

Information is also displayed if IP addresses are set on the individual detail screens.

NOTE

- For more information on the system screen layout, refer to '[8 Operations and Functions](#) p. 41'.
-

7-1-3 Accessing the system with a local connection

Launch the Internet browser, then enter the following URL:

<http://aaa.bbb.ccc.ddd/usr/viewon/Screen.shtm>

Enter the GADMS Lite (Ewon Flexy 205) IP address in place of “aaa.bbb.ccc.ddd”.

Example (with default setting): <http://192.168.100.101/usr/viewon/Screen.shtm>

Enter your user name and password to log in.

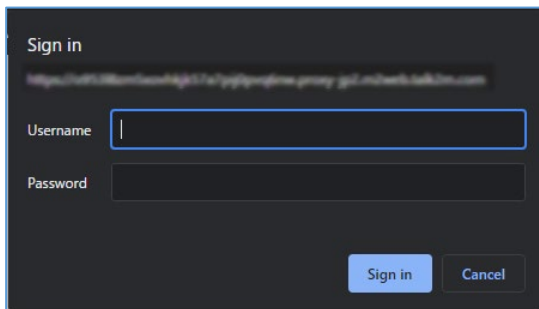

General users (viewing only, setting not permitted)

User name: “user”

Initial password: “user”

Operators (setting permitted)

User name: “admin”

Initial password: “admin”

The startup screen appears, enabling access to the system.

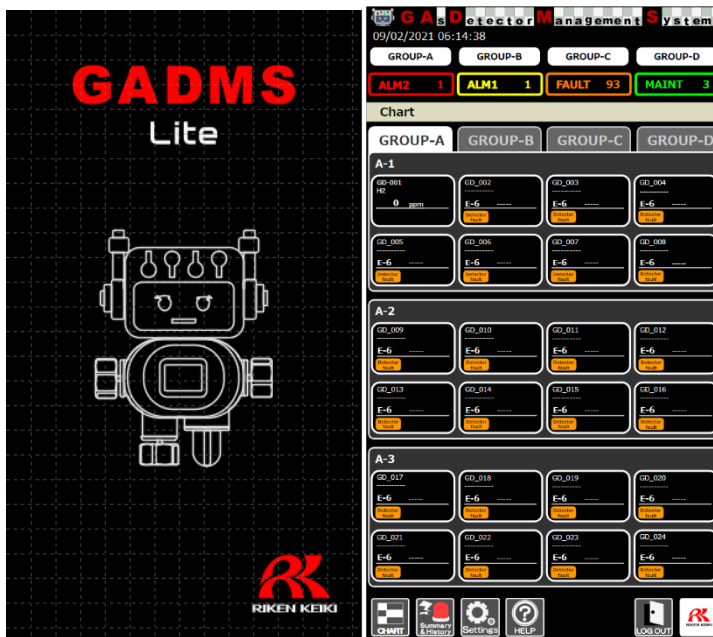

NOTE

- We recommend Google Chrome as the Internet browser.
- Operation may be slow when using for the first time.
- Before using for the first time, we recommend performing the procedure described in '[7-3-6 Disabling auto-refresh p. 40](#)'.

7-2 Using the system connected to the Internet

To use the system connected to the Internet, a Talk2M account (Talk2M Free+ plan) must be created and the account linked to the product after connecting the system to the Internet. The explanation here describes the procedure for connecting the system described in '[7-1 Using the system with a local connection p. 20](#)' to the Internet.

Items required for setup

- Internet connection (The user is responsible for obtaining the necessary contract and configuring the peripheral equipment.)
- SD card for setup (2 GB card provided with the product)
- PC
- Card reader (Provide if required to connect to the PC.)

7-2-1 Connecting the Ewon Flexy 205 (GADMS Lite) to the Internet (via router, etc.)

Connect as shown in the following diagram.

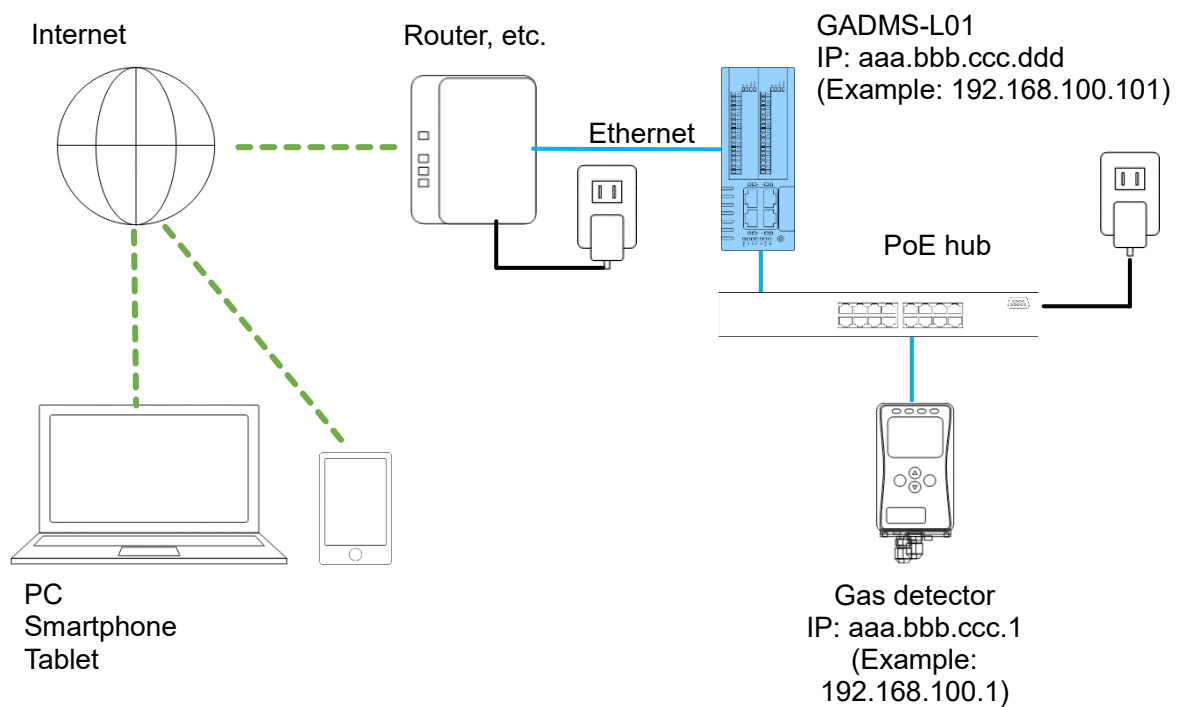

NOTE



Connect the Internet connection to the WAN port. (Refer to '[5-1 Terminal plate specifications p. 11](#)' and the Ewon Flexy 205 Specifications.)

7-2-2 Creating a Talk2M account

Install the eCatcher application on to the PC.

<https://www.ewon.biz/technical-support/pages/talk2m/talk2m-tools/talk2m-ecatcher>

©HMS Industrial Networks

Resources for eCatcher Desktop			
SOFTWARE			
File	Version	Size	Download
eCatcher Prerelease	PR 6.7.1	66.81 MB	 Download
eCatcher	6.6.4	79.17 MB	 Download

Launch eCatcher, then click ① [Create a Free+ Account].

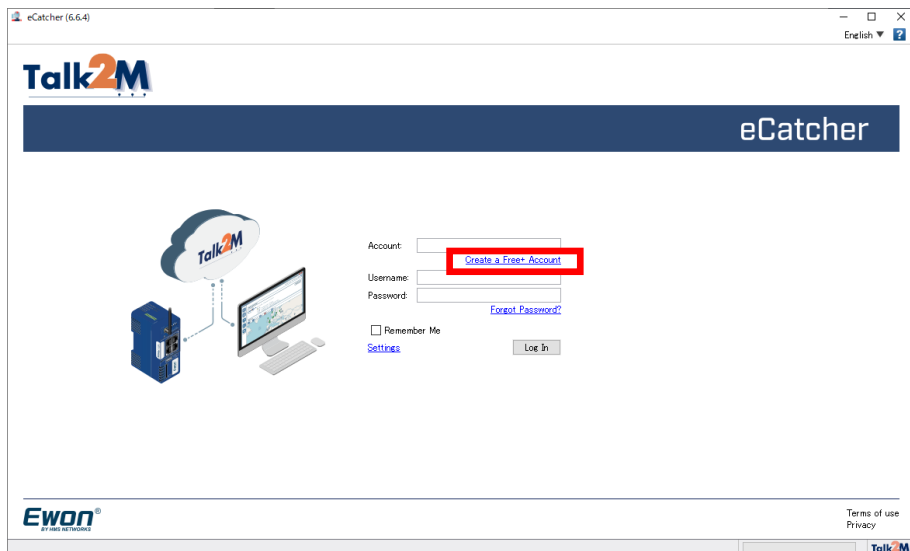

Enter the required information to set the account.

2

2 Account Name: check availability

Username:

First Name:

Last Name:

E-mail:

Confirm Email:
This email address will be used for the account activation.

Password:

Confirm Password:

3

Account Name must not be empty

2

Account Name:

Username:

First Name:

Last Name:

E-mail:

Confirm Email:

Password:

Confirm Password:

Once all details are entered, click **3** [Next].

4

4 Company Name: Company Name must not be empty

Address:

Post Code:

City:

Country:

Company Profile:

Industry Sector:

Language:

I accept the [terms of use](#).

5

4

Company Name:

Address:

Post Code:

City:

Country:

Company Profile:

Industry Sector:

Language:

Once all details are entered, click **5**

[Create].

6

6

6

6 **Congratulations**

Your Talk2M Account Test_01 is successfully registered.

In order to complete account creation, you have to activate it.
The activation procedure was sent by mail to r-higurashi@nkenkeiki.co.jp.
Please check your mails.

Once all required details are entered and the account is successfully created, the screen shown on the left appears.

Click **6** [Close].

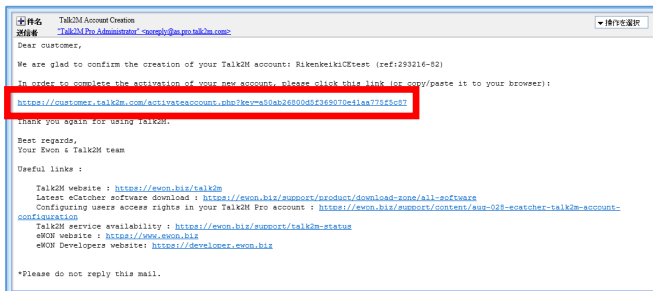

Connect to the URL provided in the email sent to the address entered earlier.

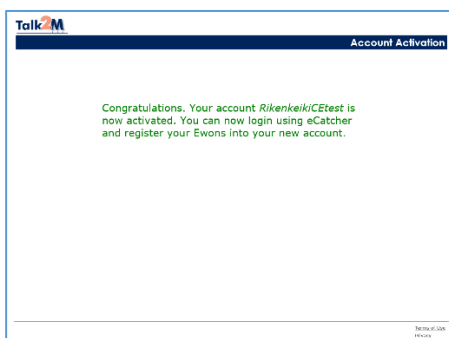

The screen above appears when account creation is complete.



CAUTION

- Keep the information about the account created in a safe place.

7-2-3 Registering the Ewon to the account created

Connect the SD card to the PC. (The actual method for connecting will vary depending on the PC.)

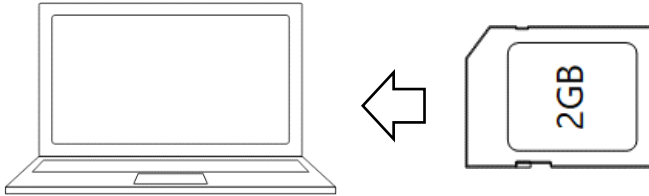

Launch eCatcher.

Enter the ① account name, user name, and password, then click ② [Log In].

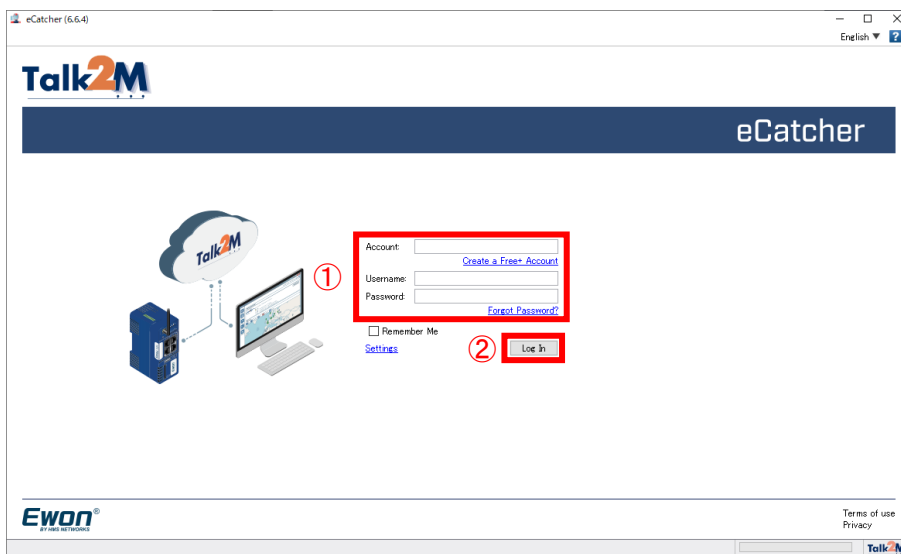

Click ③ [Add] on the My Ewons list.

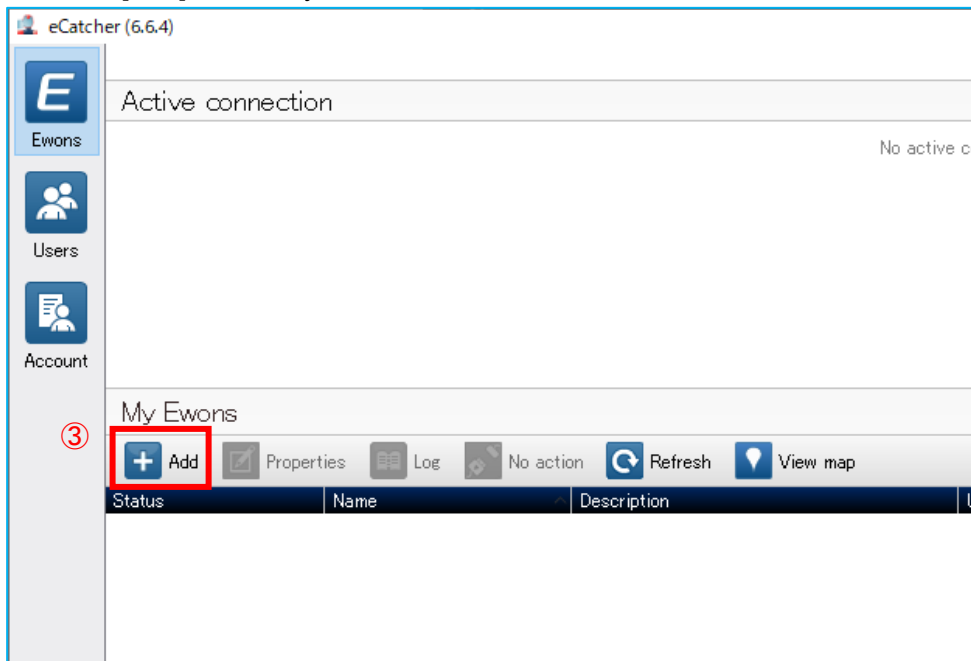

Enter ④ an Ewon name (optional), then click ⑤ [Next].

New Ewon

④ Ewon Name: Riken_EWON_1

Ewon Description:

Connection Type: Permanent

⑤ Next > Cancel

Click ⑥ [Create].

New Ewon

Custom Field 1

Custom Field 2

Custom Field 3

⑥ < Back Create Cancel

Click ⑦ [Launch Setup Wizard] for [USB / SD Card].

eCatcher (6.6.4) Risa Higuchi [Riken] Test_01 [ref: 363017-40] Logout English ?

Talk2M Connectivity: Riken_EWON_1

Back to Ewon list

Select your preferred method to configure your Ewon:

USB / SD Card

Create a USB or SD card configuration to connect your Ewon to your Talk2M account. Firmware version ≥ 13.2 is required, but we recommend FW 13.3 which offers enforced encryption.

Launch Setup Wizard ⑦

Activation Key

Every Ewon is assigned an Activation Key during its creation in Talk2M. This key cannot be changed.

Activation Key: 212cae7a23018bed3e74d87bfe184219 Copy to Clipboard

Ewon Name

Ewon Name: Riken_EWON_1 Copy to Clipboard

SMS

Send an SMS to the Ewon with its activation key. It will trigger the remote auto-configuration.

Send SMS to Ewon

Activation by SMS is only possible for "Connection Triggered" Ewon.

Settings

EWON BY ANS NETWORKS

Monitor easily KPI's with your Flexy

VPN usage: 0% Talk2M

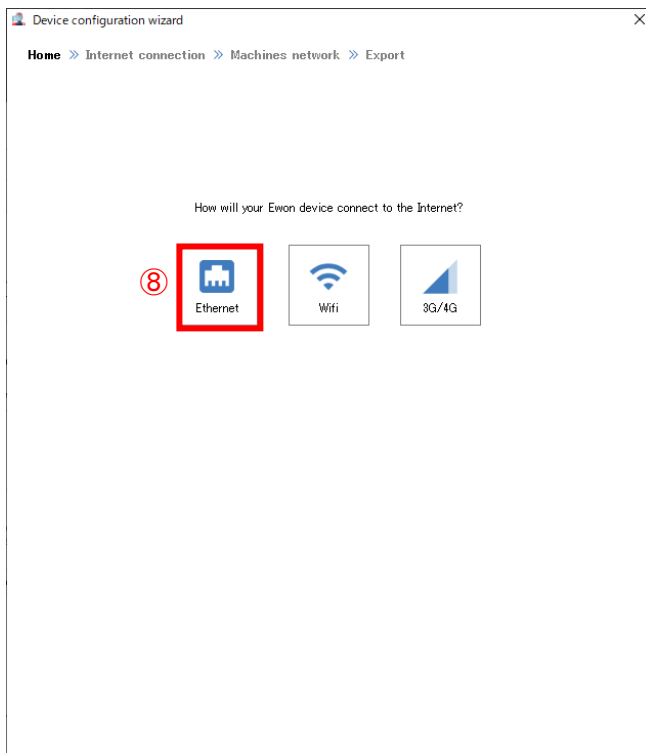

Select ⑧ [Ethernet].

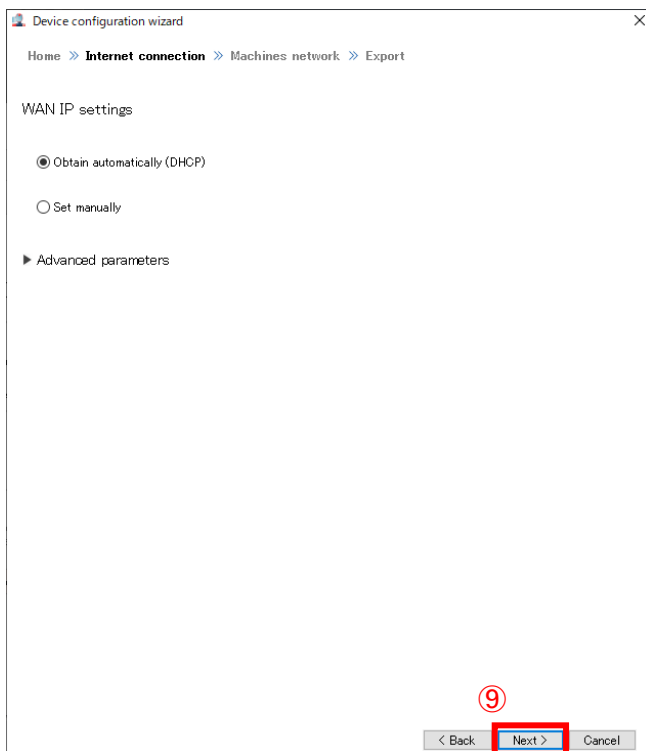

Click ⑨ [Next].

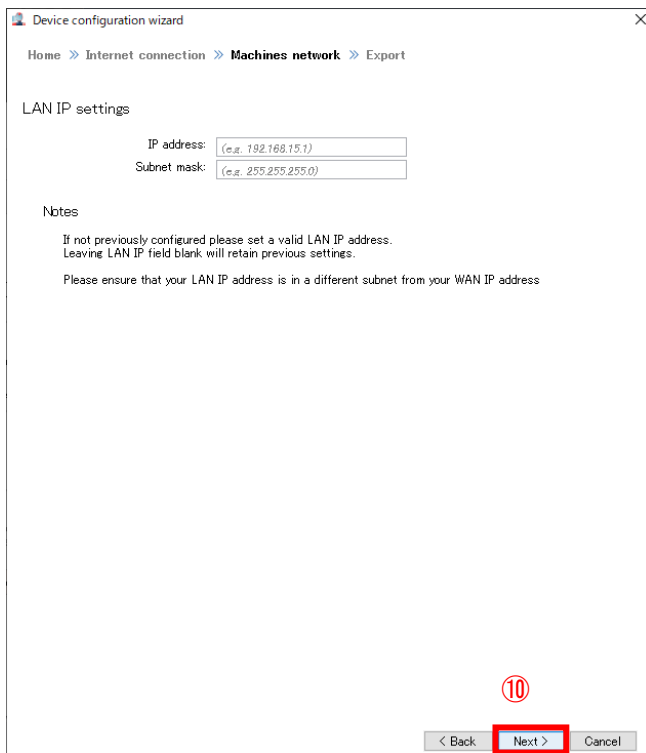

Without entering anything, click

⑩ [Next].

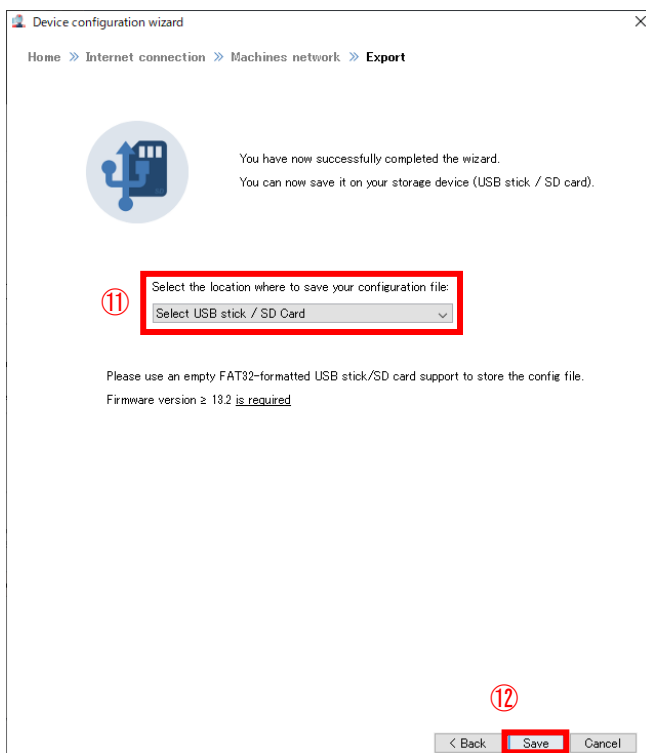

Select the SD card on which to add the setup file from the ⑪ pull-down menu, then click ⑫ [Save]. Once saving is complete, remove the SD card.

7-2-4 Loading the setup file to the Ewon Flexy 205

- Connect power supply to the Ewon Flexy 205.
- Remove the SD card for saving data from the Ewon Flexy 205 SD card slot (③), then insert the SD card on which the setup file was added.
- The USR lamp (①, second lamp from top) starts to flash. Wait until the lamp is continuously lit.
(Takes approximately one to three minutes.)
- Once the lamp is continuously lit, remove the SD card. The Ewon Flexy 205 restarts automatically.
- After restart, wait until the T2M lamp (①, second lamp from bottom) lights up.
(Takes up to approximately five minutes.) Setup is complete once the lamp is lit.
- After completing setup, insert the SD card for saving data.

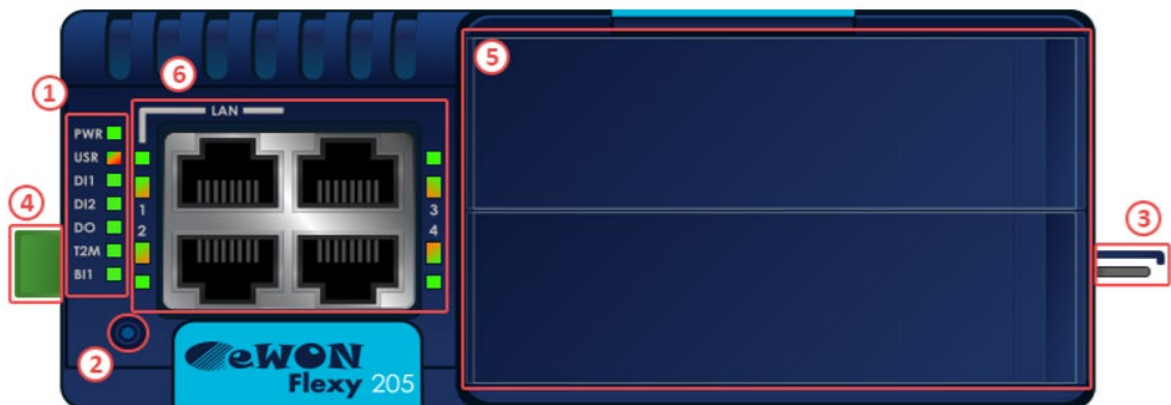

CAUTION

- Don't forget to reinsert the SD card for saving data after completing setup.
-

7-2-5 Accessing the system by connecting to the Internet

Launch the Internet browser, then access the following URL:

<https://m2web.talk2m.com/>

On the login screen, enter your account name, user name, and password, then click [Connect].

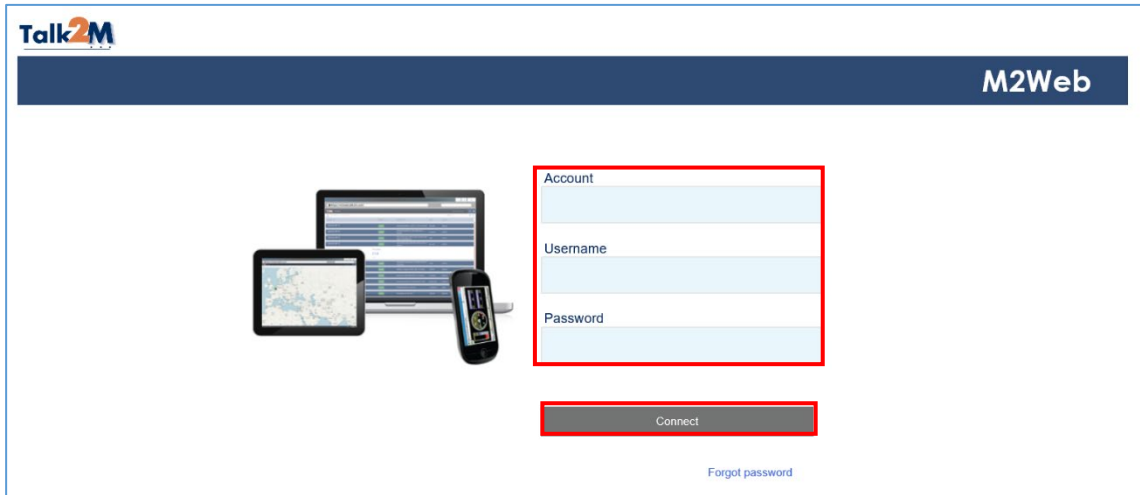

The following screen appears if login is successful. Click [Ewon].

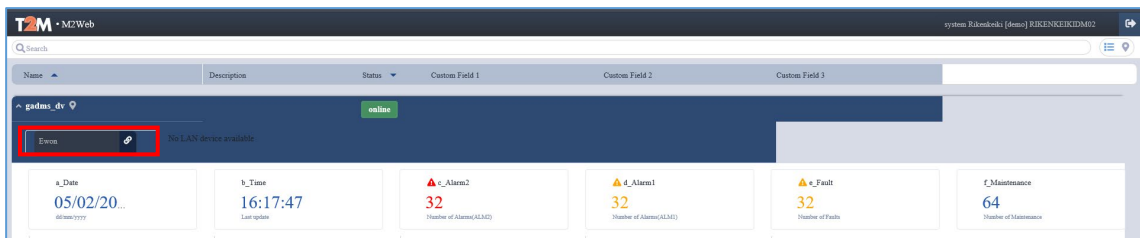

Enter your user name and password, then click [Sign in].

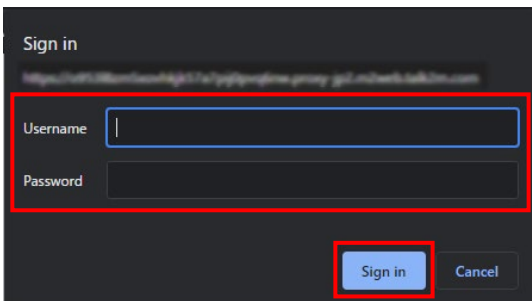

General users (viewing only, setting not permitted)

User name: "user"

Initial password: "user"

Operators (setting permitted)

User name: "admin"

Initial password: "admin"

The system can now be accessed.



NOTE

- If a Talk2M free account (Talk2M Free+) was created, up to 3 Gbytes of data traffic is allowed per month when connecting to the Internet, including display functions (excluding local connections). Data transmission will switch to slow speed mode if this data traffic is exceeded. Up to five simultaneous mobile connections are possible.
 - For more information about plan details, refer to <https://www.ewon.biz/ja/products/Talk2M> (©HMS Industrial Networks).
-

7-3 Configuring various settings

To configure various settings, first log in to the system with operator rights, then select the Settings screen.

Access the Settings screen using the ① menu button.

After accessing the Settings screen, click ② [Settings]. The Ewon Flexy setup screen appears. If you are prompted to log in, enter your user name and password to log in before clicking [Settings] once again.

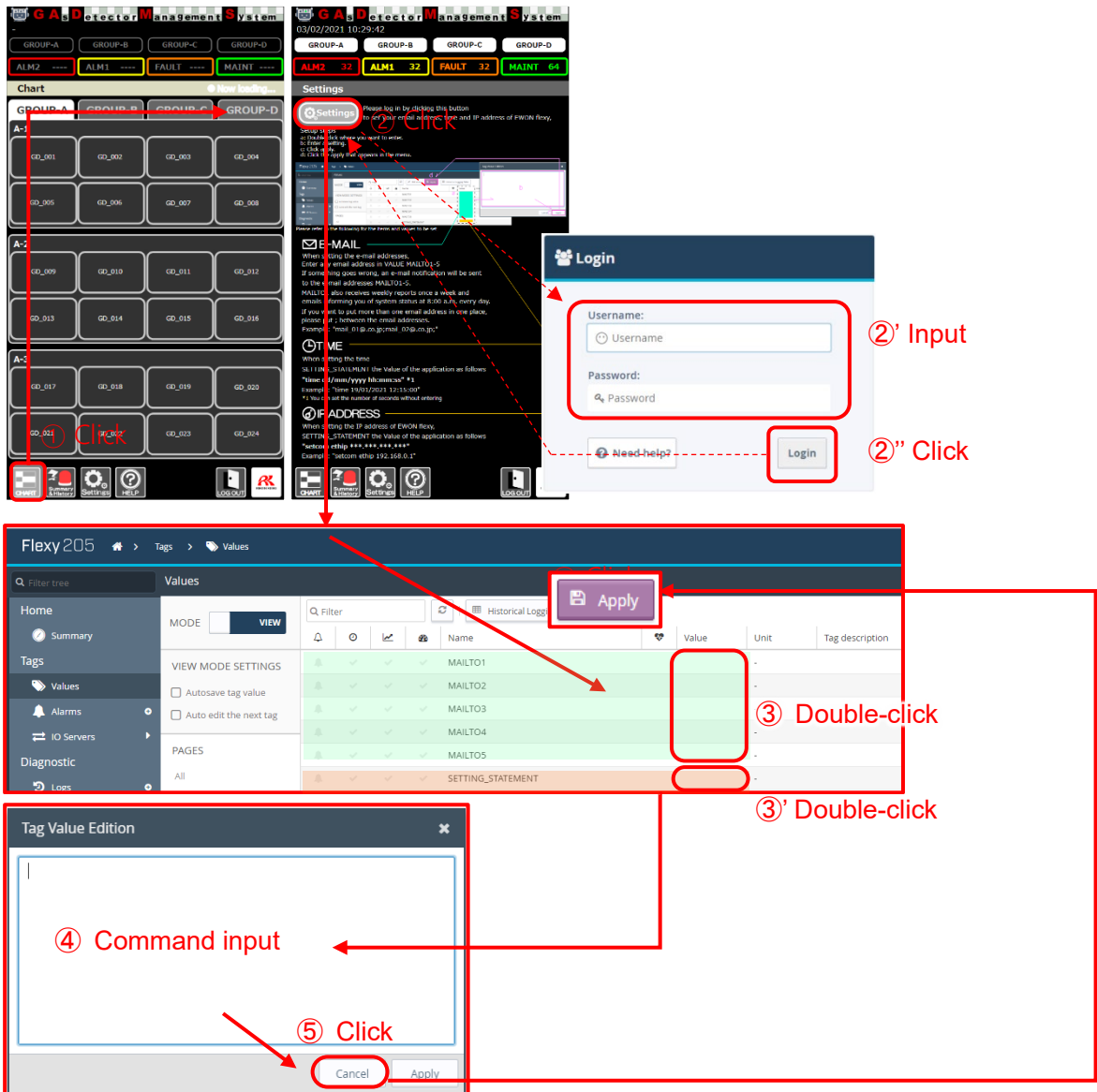

7-3-1 Setting email addresses

Connect to the Internet to allow emails to be sent.

Email types:

Alarms: Emails sent when an alarm occurs

Reports: Daily reports (8 am daily) and weekly reports (once a week)

MAILTO1 Alarms + Reports

MAILTO2 Alarms

MAILTO3 Alarms

MAILTO4 Alarms

MAILTO5 Alarms

Only MAILTO1 allows both Alarms and Reports to be sent.

Specify email addresses as follows:

Double-click the [Value] column for ③ [MAILTO1] - [MAILTO5].

Enter the email address in the ④ dialog box.

aaa@xxx.co.jp;aaa@yyy.co.jp

Click ⑤ [Apply], then click the ⑥ [Apply] button that appears in the upper menu. The command is entered and the recipient email address is registered/updated.

7-3-2 Setting the email header

Double-click the [Value] column for [MAIL_HEADER].

Enter the desired email header in the ④ dialog box displayed.

Click ⑤ [Apply], then click the ⑥ [Apply] button that appears in the upper menu.

7-3-3 Altering the GADMS-L01 IP address

Change the IP address to an appropriate address in accordance with your system setup.

Change the IP address as follows:

• Entering a new IP address

Double-click the [Value] column for ③ [SETTING_STATEMENT].

Enter the following in the ④ dialog box displayed:

syscom ethip aaa.bbb.ccc.ddd (example: syscom ethip 123.456.789.200)

* Enter your own IP address in place of aaa.bbb.ccc.ddd. (ddd = 97 - 254)

Make sure IP addresses are not duplicated if any PCs are connected locally.

Click ⑤ [Apply], then click the ⑥ [Apply] button that appears in the upper menu.

- **Saving settings**

Now enter the following in the ④ dialog box:

save

Click ⑤ [Apply] again, then click the ⑥ [Apply] button that appears in the upper menu.
The command is entered and the setting is saved.

- **Restarting**

Now enter the following in the ④ dialog box:

reboot

Click ⑤ [Apply] again, then click the ⑥ [Apply] button that appears in the upper menu.
The command is entered and the setting is saved.

This completes the procedure for changing the Ewon Flexy 205 (GADMS Lite) IP address. The gas detector and PC (local connection) IP addresses must also be changed after changing the Ewon Flexy 205 IP address.

7-3-4 Setting the time (Only when using a local connection)

Double-click the [Value] column for ③' [SETTING_STATEMENT].

Enter the following in the ④ dialog box:

time dd/mm/yyyy hh:mm:ss (example: "time 30/01/2020 17:10:30")

Click ⑤ [Apply], then click the ⑥ [Apply] button that appears in the upper menu. The command is entered and the time is updated.

When connected to the Internet, the time is set automatically. The time will not be altered even if this procedure is performed.

7-3-5 Changing the Ewon Flexy 205 (GADMS Lite) login password

- **Changing the password for Username: admin (operator rights)**

Double-click the [Value] column for ③' [SETTING_STATEMENT].

Enter the following in the ④ dialog box:

sysuser admin password *****

Click ⑤ [Apply], then click the ⑥ [Apply] button that appears in the upper menu. The command is entered and the password is updated.

- **Changing the password for Username: user (general user)**

Double-click the [Value] column for ③ [SETTING_STATEMENT].

Enter the following in the ④ dialog box:

sysuser user password *****

Click ⑤ [Apply], then click the ⑥ [Apply] button that appears in the upper menu. The command is entered and the password is updated.

7-3-6 Disabling auto-refresh

The screenshot shows the 'Flexy 205' web interface. The top navigation bar includes 'Home', 'Tags', and 'Values'. The user is logged in as 'adm'. The left sidebar contains navigation options: Home (Summary), Tags (Values, Alarms, IO Servers), Diagnostic (Logs, Status, Files Transfer), and Setup. The main content area is titled 'Values' and shows a table of tag values. The table has columns for Name, Value, Unit, and Tag description. The 'Autorefresh' checkbox is checked, and the rate is set to 1 second. The table lists various tags such as MAILTO1 through MAILTO5, MAIL_HEADER, SETTING_STATEMENT, and GD_001_VALUE through GD_017_VALUE. The bottom status bar shows 'Ewon Name: Ewon', 'Firmware: 14.2s0 (#1190)', 'S/N: 2032-0320-24', 'Current time: 21/09/2021 08:55:30', and 'Status'.

Unselect the check box.



CAUTION

- Please keep a record of the new password in a safe place.
A Riken Keiki representative must visit the site to reset the password if you lose the password.

8-2 Chart (list screen)

This screen displays the gas detector status. This is the main screen displayed when the system starts up.

Gas Detector Management System
03/02/2021 10:28:45

GROUP-A GROUP-B GROUP-C GROUP-D

ALM2 32 **ALM1 32** **FAULT 32** **MAINT 64**

Chart

GROUP-A GROUP-B GROUP-C GROUP-D

A-1

GD-001 H2 1210 ppm ALM1 ALM2	GD_002 CL2 1.32 ppm ALM1	CH4-001 Ash3 E-1 ppm Sensor fault	GD-001 H2 1210 ppm ALM1 ALM2
GD_002 CL2 1.32 ppm ALM1	CH4-001 Ash3 E-1 ppm Sensor fault	GD-001 H2 1210 ppm ALM1 ALM2	GD_002 CL2 1.32 ppm ALM1

A-2

CH4-001 Ash3 E-1 ppm Sensor fault	GD-001 H2 1210 ppm ALM1 ALM2	GD_002 CL2 1.32 ppm ALM1	CH4-001 Ash3 E-1 ppm Sensor fault
GD-001 H2 1210 ppm ALM1	GD_002 CL2 1.32 ppm ALM1	CH4-001 Ash3 E-1 ppm Sensor fault	GD-001 H2 1210 ppm ALM1 ALM2

A-3

GD_002 CL2 1.32 ppm ALM1	CH4-001 Ash3 E-1 ppm Sensor fault	GD-001 H2 1210 ppm ALM1 ALM2	GD_002 CL2 1.32 ppm ALM1
CH4-001 Ash3 E-1 ppm Sensor fault	GD-001 H2 1210 ppm ALM1 ALM2	GD_002 CL2 1.32 ppm ALM1	CH4-001 Ash3 E-1 ppm Sensor fault

CHART **Summary & History** **Settings** **HELP** **LOG OUT** **RIKEN KEIKI**

①

②

③

① Title information

Displays the current time and important information on system status and all gas detectors installed on the system.

Normal state

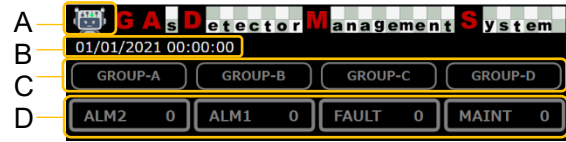

Alarm state and when configuring settings



- A Indicates whether the system is operating normally. The display changes when an alarm occurs.
- B Displays the current time.
- C Indicates the group in which an alarm has occurred. The group name lights up in white when an alarm occurs.
- D Indicates gas detector alarms, alarm type, and number of alarms. The indications light up or flash depending on the status.

② Gas detector information

Displays the individual gas detector settings, readings, and status. More detailed information can be checked by clicking the corresponding part on the screen to display the details screen.

* Up to 24 points can be displayed per screen, with four screens (groups) giving a total of 96 points.

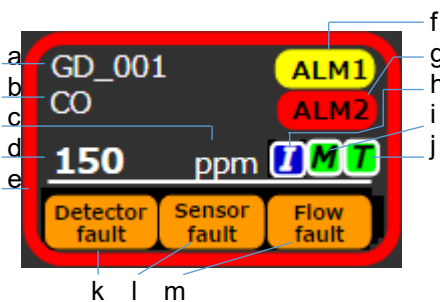

n.G_Maint status

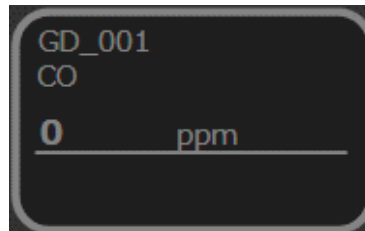

o.Not available status



- a. Displays the tag name.
- b. Displays the gas name.
- c. Displays the units.
- d. Displays the concentration reading. E-1 is displayed when a fault occurs.
- e. Lights up white when normal, red for ALM2, and yellow for ALM1.
- f. Flashes for ALM1.
- g. Flashes for ALM2.
- h. Lights up for inhibit mode.
- i. Lights up for maintenance mode.
- j. Lights up for test mode.
- k. Flashes for a detector fault.
- l. Flashes for a sensor fault.
- m. Flashes for a flow rate abnormality.
- n. Grayed out for G_Maint status.
- o. The tag name and other details disappear in Not available status, leaving only the location number displayed.

NOTE

For more information on G_Maint and Not available status, refer to '[8-3 Details \(details screen\) p. 45](#)'.

③ Icons (identical for all screens)

Click or touch the icons to load the corresponding screens.

A: Chart (list screen), B: Summary & History (alarm history screen), C: Settings (settings screen), D: HELP (brief explanation), E: LOG OUT (log-out), F: RK logo (Riken Keiki website)



NOTE

C: Settings (setting screen) is displayed only when you have logged in with operator rights.

8-3 Details (details screen)

Displays detailed information for a single gas detector. It also allows the gas detector status to be set on the system.

Gas Detector Management System
03/02/2021 10:50:02

GROUP-A GROUP-B GROUP-C GROUP-D

ALM2 32 **ALM1 32** **FAULT 32** **MAINT 64**

Gas Detector Details

Available / Not available G_Maint

Gas alarm (ALM2)
Gas alarm (ALM1)
Detector fault
Sensor fault
Flow fault
Maintenance
Test
Inhibit

No.	GD_001
IP Address	192.168.11.01
Tag No.	GD-001
Sensor	H2
Range	2000 ppm
ALM1	500 ppm
ALM2	1000 ppm
Sampling location	MACHINE1

VIEW Settings: Click here to open the configuration information. You can check the setting value of the gas detector.

MODIFY Settings: Click here to open the configuration setting page. Options for maintenance mode and configuration changes are available through this menu. You will be prompted to enter a password.

CHART Summary & History Settings HELP LOG OUT RIKEN KEIKI

① Status selector switch

Click or touch to switch the status.

The screen display will change in accordance with the status selected.

Available

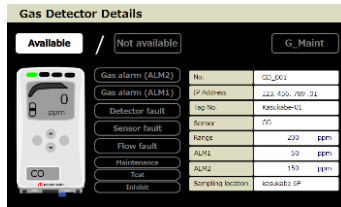

G_Maint

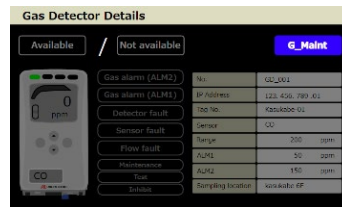

Not available



Available: Normal detection status

G_Maint: Disables alarms on the system.

Not available: No gas detector is available on the system



CAUTION

- An alarm may be issued depending on the gas detector and system status when the status switches from G_Maint or Not available to Available. Make sure the devices connected are thoroughly protected in accordance with the status. Riken Keiki rejects all responsibility for any secondary damages.

NOTE

- This can be viewed and used only when you have logged in with operator rights.

② Gas detector information display

You can check measured gas concentrations and the gas detector setting status.

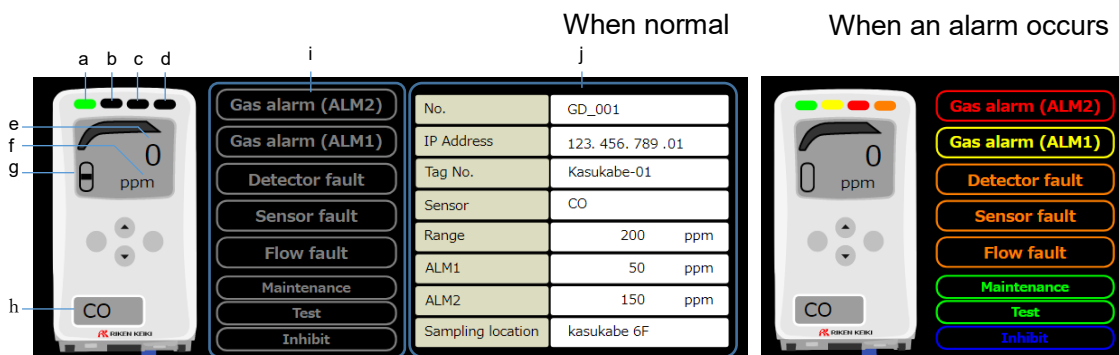

- Normally lit up in green. Goes out if a detector fault occurs.
- Lights up in yellow for ALM1.
- Lights up in red for ALM2.
- Lights up in orange if a fault occurs.
- Displays the concentration reading. E-1 is displayed when a fault occurs.
- Displays the units.
- Goes out in the event of a flow rate abnormality.
- Displays the gas name.
- Indicates the detector status. The indications light up according to individual status.
- Displays the detector setting information.

③ Screen selection buttons

Click or touch to move back or forward to other details screens.

← Back (Example: Move from GD_001 to GD_096 or from GD_003 to GD_002.)

→ Next (Example: Move from GD_001 to GD_002 or from GD_096 to GD_001.)

④ Gas detector setting buttons

Click or touch to move to the gas detector settings screen.

Use to shift to maintenance mode or change settings.

Example settings screen

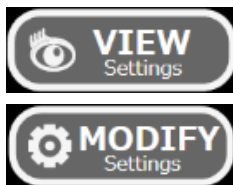

Only to view settings

To alter or test settings, etc.

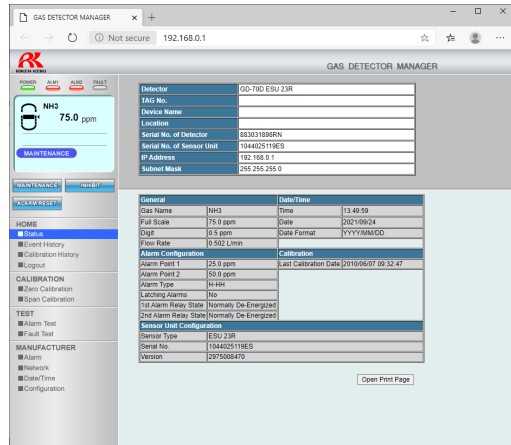

The screenshot shows the 'GAS DETECTOR MANAGER' web interface. The top navigation bar includes 'HOME', 'ALARM', and 'PRINT' buttons. The main content area is divided into several sections:

- Detector Information:** A table with fields for Detector (GG-700 ESU 23R), TAG No., Device Name, Location, Serial No. of Detector (883031899RH), Serial No. of Sensor Unit (1044025119ES), IP Address (192.168.0.1), and Subnet Mask (254.255.255.0).
- General:** A table with fields for Clock Name (Nrs3), Time (13:40:58), Full Scale (75.0 ppm), Date (2021/09/24), Digt (0.5 ppm), and Date Format (YYYYMMDD).
- Alarm Configuration:** A table with fields for Alarm Point 1 (25.0 ppm), Alarm Point 2 (5.0 ppm), Alarm Type (H-HH), Latching Alarm (No), 1st Alarm Relay State (Normally De-Energized), and 2nd Alarm Relay State (Normally De-Energized).
- Calibration:** A table with fields for Alarm Point 1 (25.0 ppm) and Last Calibration Date (2019/06/07 09:32:47).
- Manufacturer:** A table with fields for Manufacturer (ESU 23R), Serial No. (1044025119ES), Alarm, Network, Date/Time, and Version (2975008470).

The sidebar menu on the left includes options like 'VIEW Settings', 'MODIFY Settings', 'HOME', 'Status', 'Event History', 'Calibration History', 'Logout', 'CALIBRATION', 'Span Calibration', 'TEST', 'Alarm Test', 'Full Test', 'MANUFACTURER', 'Alarm', 'Network', 'Date/Time', and 'Configuration'.

NOTE

- For more information on setting procedures, refer to the operating manual for the gas detector.
- The MODIFY button is available only when you have logged in with operator rights.

8-4 Summary & History (alarm summary and history)

Displays the status of alarms that have occurred.

The screenshot displays the Gas Detector Management System interface. At the top, the title "Gas Detector Management System" is shown with a timestamp of "22/01/2021 14:13:38". Below the title are four group selection buttons: "GROUP-A", "GROUP-B", "GROUP-C", and "GROUP-D". A status bar shows four categories: "ALM2 32" (highlighted in red), "ALM1 32" (highlighted in yellow), "FAULT 0" (highlighted in grey), and "MAINT 96" (highlighted in green). The main section is titled "Alarm Summary" and contains a table with columns: "Ack", "Date", "Tag", "Action/Date", "User Ack", and "Description". The table lists 32 alarm entries, each with a checkbox in the "Ack" column and a description of the alarm type and time. A red circle labeled "1" is positioned to the right of the table. Below the table are two buttons: "History" (highlighted in red with a red circle labeled "2") and "Logging" (highlighted in red with a red circle labeled "3"). At the bottom of the interface are icons for "CHART", "Summary & History", "Settings", "HELP", "LOG OUT", and the "RORSSA" logo.

Ack	Date	Tag	Action/Date	User Ack	Description
<input type="checkbox"/>	22/01/2021 13:53:43	GD_001_ALA	ALM (HIMI) 22/01/2021 13:53:43		HI(1)=1st HIHI(2)=2
<input type="checkbox"/>	22/01/2021 12:15:17	GD_006_ALA	ALM (HI) 22/01/2021 12:15:17		HI(1)=1st HIHI(2)=2
<input type="checkbox"/>	22/01/2021 12:15:17	GD_009_ALA	ALM (HI) 22/01/2021 12:15:17		HI(1)=1st HIHI(2)=2
<input type="checkbox"/>	22/01/2021 12:15:17	GD_092_ALA	ALM (HI) 22/01/2021 12:15:17		HI(1)=1st HIHI(2)=2
<input type="checkbox"/>	22/01/2021 12:15:16	GD_069_ALA	ALM (HI) 22/01/2021 12:15:16		HI(1)=1st HIHI(2)=2
<input type="checkbox"/>	22/01/2021 12:15:16	GD_071_ALA	ALM (HI) 22/01/2021 12:15:16		HI(1)=1st HIHI(2)=2
<input type="checkbox"/>	22/01/2021 12:15:16	GD_074_ALA	ALM (HI) 22/01/2021 12:15:16		HI(1)=1st HIHI(2)=2
<input type="checkbox"/>	22/01/2021 12:15:16	GD_077_ALA	ALM (HI) 22/01/2021 12:15:16		HI(1)=1st HIHI(2)=2
<input type="checkbox"/>	22/01/2021 12:15:16	GD_080_ALA	ALM (HI) 22/01/2021 12:15:16		HI(1)=1st HIHI(2)=2
<input type="checkbox"/>	22/01/2021 12:15:16	GD_083_ALA	ALM (HI) 22/01/2021 12:15:16		HI(1)=1st HIHI(2)=2
<input type="checkbox"/>	22/01/2021 12:15:15	GD_053_ALA	ALM (HI) 22/01/2021 12:15:15		HI(1)=1st HIHI(2)=2
<input type="checkbox"/>	22/01/2021 12:15:15	GD_056_ALA	ALM (HI) 22/01/2021 12:15:15		HI(1)=1st HIHI(2)=2
<input type="checkbox"/>	22/01/2021 12:15:15	GD_059_ALA	ALM (HI) 22/01/2021 12:15:15		HI(1)=1st HIHI(2)=2
<input type="checkbox"/>	22/01/2021 12:15:15	GD_062_ALA	ALM (HI) 22/01/2021 12:15:15		HI(1)=1st HIHI(2)=2
<input type="checkbox"/>	22/01/2021 12:15:15	GD_065_ALA	ALM (HI) 22/01/2021 12:15:15		HI(1)=1st HIHI(2)=2
<input type="checkbox"/>	22/01/2021 12:15:14	GD_035_ALA	ALM (HI) 22/01/2021 12:15:14		HI(1)=1st HIHI(2)=2
<input type="checkbox"/>	22/01/2021 12:15:14	GD_038_ALA	ALM (HI) 22/01/2021 12:15:14		HI(1)=1st HIHI(2)=2
<input type="checkbox"/>	22/01/2021 12:15:14	GD_041_ALA	ALM (HI) 22/01/2021 12:15:14		HI(1)=1st HIHI(2)=2
<input type="checkbox"/>	22/01/2021 12:15:14	GD_044_ALA	ALM (HI) 22/01/2021 12:15:14		HI(1)=1st HIHI(2)=2
<input type="checkbox"/>	22/01/2021 12:15:14	GD_047_ALA	ALM (HI) 22/01/2021 12:15:14		HI(1)=1st HIHI(2)=2
<input type="checkbox"/>	22/01/2021 12:15:14	GD_050_ALA	ALM (HI) 22/01/2021 12:15:14		HI(1)=1st HIHI(2)=2
<input type="checkbox"/>	22/01/2021 12:15:13	GD_020_ALA	ALM (HI) 22/01/2021 12:15:13		HI(1)=1st HIHI(2)=2
<input type="checkbox"/>	22/01/2021 12:15:13	GD_023_ALA	ALM (HI) 22/01/2021 12:15:13		HI(1)=1st HIHI(2)=2
<input type="checkbox"/>	22/01/2021 12:15:13	GD_026_ALA	ALM (HI) 22/01/2021 12:15:13		HI(1)=1st HIHI(2)=2
<input type="checkbox"/>	22/01/2021 12:15:13	GD_029_ALA	ALM (HI) 22/01/2021 12:15:13		HI(1)=1st HIHI(2)=2
<input type="checkbox"/>	22/01/2021 12:15:13	GD_032_ALA	ALM (HI) 22/01/2021 12:15:13		HI(1)=1st HIHI(2)=2
<input type="checkbox"/>	22/01/2021 12:15:12	GD_005_ALA	ALM (HI) 22/01/2021 12:15:12		HI(1)=1st HIHI(2)=2
<input type="checkbox"/>	22/01/2021 12:15:12	GD_008_ALA	ALM (HI) 22/01/2021 12:15:12		HI(1)=1st HIHI(2)=2
<input type="checkbox"/>	22/01/2021 12:15:12	GD_011_ALA	ALM (HI) 22/01/2021 12:15:12		HI(1)=1st HIHI(2)=2
<input type="checkbox"/>	22/01/2021 12:15:12	GD_014_ALA	ALM (HI) 22/01/2021 12:15:12		HI(1)=1st HIHI(2)=2

① Alarm summary

Lists the alarm that have occurred. If no alarms have occurred, nothing is displayed.

② Alarm history

Click or touch [History] to display the history confirmation screen.

You must log in to the Ewon Flexy 205 beforehand. Click or touch the button again after login.

③ Record/trend data

Click or touch [Logging] to display the data confirmation screen.

You must log in to the Ewon Flexy 205 beforehand. Click or touch the button again after login.

8-5 Settings (setting information screen)

Displays the status of alarms that have occurred.

Gas Detector Management System
22/01/2021 14:14:13

GROUP-A GROUP-B GROUP-C GROUP-D

ALM2 32 **ALM1 32** **FAULT 0** **MAINT 96**

Settings

① **Settings** Please log in by clicking this button
to set your email address, time and IP address of EWON flexy,

Setup steps
a: Double-click where you want to enter.
b: Enter a setting.
c: Click apply.
d: Click the apply that appears in the menu.

Please refer to the following for the items and values to be set.

E-MAIL
When setting the e-mail addresses,
Enter any email address in VALUE MAILTO1-5
If something goes wrong, an e-mail notification will be sent
to the e-mail addresses MAILTO1-5.
MAILTO1 also receives weekly reports once a week and
emails informing you of system status at 8:00 a.m. every day.
If you want to put more than one email address in one place,
please put ; between the email addresses.
Example: "mail_01@.co.jp;mail_02@.co.jp;"

TIME
When setting the time
SETTING_STATEMENT the Value of the application as follows
"time dd/mm/yyyy hh:mm:ss" *1
Example: "time 19/01/2021 12:15:00"
*1 You can set the number of seconds without entering

IP ADDRESS
When setting the IP address of EWON flexy,
SETTING_STATEMENT the Value of the application as follows
"setcom ethip *.*.*.*.*.*"
Example: "setcom ethip 192.168.0.1"

CHART Summary & History Settings HELP LOG OUT KISHI KEN

① **Link button to dedicated settings screen**

Click to access the dedicated settings screen and configure individual settings.

The following items can be set:

- Email addresses
- Email header
- Time (acquired automatically when connected to the Internet)
- IP address

For more information on setting procedures, refer to '[7-3 Configuring various settings](#)
[p. 37](#)'.

NOTE

- This can be viewed and used only when you have logged in with operator rights.
-

8-6 Email function

The product incorporates a function for sending email notifications to registered email addresses when an alarm occurs while connected to the Internet. In addition to these notifications, periodic report emails can also be sent to a representative email address (MAILTO1).

Two kinds of periodic report emails are available. These consist of a daily report that indicates whether the system is operating sent daily at 8 am and a weekly report sent once a week.

8-6-1 Example email content

When an alarm has occurred

Provides information on the alarm time, type of alarm, corresponding tag name, gas type, concentration, and location.

Subject: Gas alarm! ---RIKENKEIKI---

(In case of alarm test: *** TEST *** Gas alarm! ---RIKENKEIKI---)

Body

Header set by user (MAIL HEADER)

08:33:37 Alarm1 No.002 GD_002	CL2	2.00 ppm	ROOM-A
08:33:37 Alarm1 No.005 GD_002	CL2	2.00 ppm	ROOM-A
08:33:37 Alarm1 No.008 GD_002	CL2	2.00 ppm	ROOM-A
08:33:38 Alarm1 No.011 GD_002	CL2	2.00 ppm	ROOM-A
08:33:38 Alarm1 No.014 GD_002	CL2	2.00 ppm	ROOM-A

When a fault alarm has occurred

Provides information on the fault alarm time, type of fault, corresponding tag name, gas type, and location.

Subject: Fault alarm! ---RIKENKEIKI---

Body

Header set by user (MAIL HEADER)

18:59:04 Sensor fault No.003 CH4-001	AsH3	KASUKABE DC 6F
18:59:04 Sensor fault No.006 CH4-001	AsH3	KASUKABE DC 6F
18:59:04 Sensor fault No.009 CH4-001	AsH3	KASUKABE DC 6F
18:59:05 Sensor fault No.012 CH4-001	AsH3	KASUKABE DC 6F
18:59:05 Sensor fault No.015 CH4-001	AsH3	KASUKABE DC 6F

Daily report

Provides information on the alarm time, type of (fault) alarm, corresponding tag name, gas type, and location.

Subject

GADMS report

Body

Daily report: Gas detector management system is operating normally.

Alarm history of last day.

"EventDate";"TagName";"Status";"Type";"UserAck";"Description"

"07/02/2021 18:19:23";"GD_001_ALARM";"ALM";"HI";"";"HI=1st HIHI=2nd"

"07/02/2021 18:59:03";"GD_001_ALARM";"ALM";"HIHI";"";"HI=1st HIHI=2nd"

"07/02/2021 18:59:16";"SYSTEM_FAULT";"END";"";"HI=1st HIHI=2nd"

"08/02/2021 03:51:55";"GD_070_ALARM";"END";"";"HI=1st HIHI=2nd"

"08/02/2021 03:51:55";"GD_073_ALARM";"END";"";"HI=1st HIHI=2nd"

"08/02/2021 03:51:55";"GD_076_ALARM";"END";"";"HI=1st HIHI=2nd"

"08/02/2021 03:51:56";"GD_079_ALARM";"END";"";"HI=1st HIHI=2nd"

"08/02/2021 03:51:56";"GD_082_ALARM";"END";"";"HI=1st HIHI=2nd"

"08/02/2021 03:51:56";"GD_085_ALARM";"END";"";"HI=1st HIHI=2nd"

"08/02/2021 03:51:56";"GD_088_ALARM";"END";"";"HI=1st HIHI=2nd"

Weekly report

Provides information on the alarms that occurred during the past week.

Indicates the alarm time, corresponding tag name, and (fault) alarm type.

Subject

GADMS report

Body

Weekly report: Alarm history of last week.

```
"EventDate";"TagName";"Status";"Type";"UserAck";"Description"
```

```
"07/02/2021 18:19:23";"GD_001_ALARM";"ALM";"HI";"";"HI=1st HIHI=2nd"
```

```
"07/02/2021 18:59:03";"GD_001_ALARM";"ALM";"HIHI";"";"HI=1st HIHI=2nd"
```

```
"07/02/2021 18:59:16";"SYSTEM_FAULT";"END";"";"";"";
```

```
"08/02/2021 03:51:55";"GD_070_ALARM";"END";"";"";"";"HI=1st HIHI=2nd"
```

```
"08/02/2021 03:51:55";"GD_073_ALARM";"END";"";"";"";"HI=1st HIHI=2nd"
```

```
"08/02/2021 03:51:55";"GD_076_ALARM";"END";"";"";"";"HI=1st HIHI=2nd"
```

```
"08/02/2021 03:51:56";"GD_079_ALARM";"END";"";"";"";"HI=1st HIHI=2nd"
```

```
"08/02/2021 03:51:56";"GD_082_ALARM";"END";"";"";"";"HI=1st HIHI=2nd"
```

```
"08/02/2021 03:51:56";"GD_085_ALARM";"END";"";"";"";"HI=1st HIHI=2nd"
```

```
"08/02/2021 03:51:56";"GD_088_ALARM";"END";"";"";"";"HI=1st HIHI=2nd"
```

```
"08/02/2021 03:51:57";"GD_091_ALARM";"END";"";"";"";"HI=1st HIHI=2nd"
```

```
"08/02/2021 03:51:57";"GD_094_ALARM";"END";"";"";"";"HI=1st HIHI=2nd"
```

8-7 KPI (standard M2WEB function)

This is available only when connected to the Internet. The function allows the number of alarm events to be checked easily for systems registered to a Talk2M account simply by logging in to the Talk2M account. You can register multiple systems to a single account to check the number of alarm events for multiple locations.

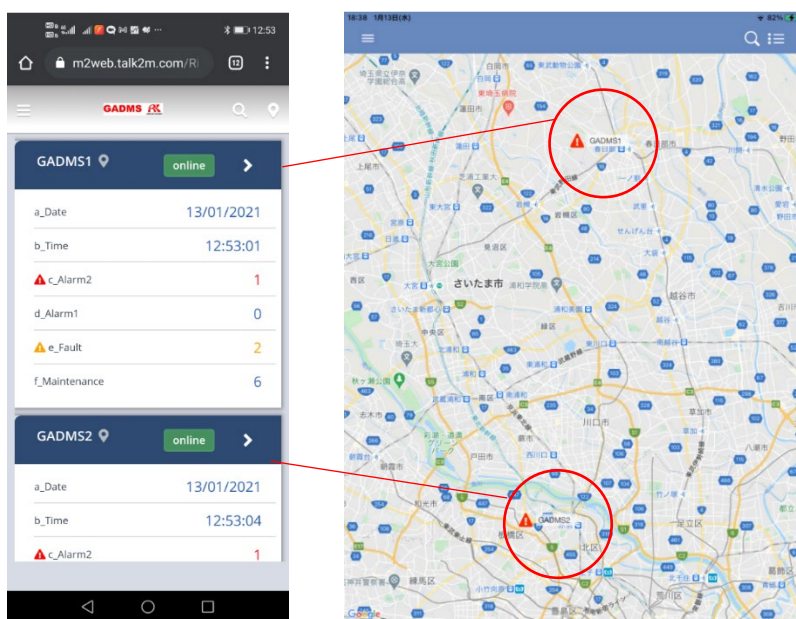

Download the dedicated app when checking from a smartphone or tablet device.

<https://www.ewon.biz/ja/products/Talk2M/vpn-client-ecatcher>

©HMS Industrial Networks

(For more information on setting procedures, refer to '7-2 Using the system connected to the Internet p. 26'.)

9 Storage, Relocation, and Disposal

9-1 Storage

Store the product under the following conditions:

- In a dark place at normal temperatures and humidity and away from direct sunlight
- In a place free of gases, solvents, and vapor
- In a place not exposed to extremely high or extremely low temperatures

9-2 Relocation

For more information on locations when relocating the product, refer to '4-2 Precautions regarding installation location p. 9' and '4-4 Installation procedure p. 10'.

9-3 Disposal

Dispose of the main unit as industrial waste (incombustible) in accordance with local regulations.

10 Troubleshooting

Symptom/display	Cause	Action
The power cannot be turned on.	The power has not been turned on. The cables have not been connected.	Connect the power supply.
	Power supply circuit abnormality/instantaneous interruption or cable abnormality (disconnected/unconnected/short circuit)	Check the wiring for this product and the related devices in the vicinity.
	Main unit abnormality	Contact Riken Keiki.
The screen is not displayed.	The cables are connected incorrectly.	Check the wiring for this product and the related devices in the vicinity.
	Not connected to the network	Check the product and peripheral device settings. Check the network status.
	The IP address set is incorrect.	Check the product and peripheral device settings.
The screen freezes.	The cables are disconnected.	Check the wiring for this product and the related devices in the vicinity.
	The Internet connection is intermittent.	Check the product and peripheral device settings. Check the network status.
Data is not displayed correctly on the screen.	The IP address set is incorrect.	Check the product and peripheral device settings.
Trend data is not saved to the SD card.	The SD card is not inserted.	Fully insert the SD card.
	The SD card is faulty.	Use a new SD card. (With capacity not exceeding 4 GB and EXT3 formatted)
Emails are not received.	Not connected to the Internet	Connect the product to the Internet. Check the product and peripheral device settings. Check the network status.
	The email address is incorrect.	Set the correct email address. (Refer to ' 7-3-1 Setting email addresses ' p. 38.)
The product operates inconsistently.	Noise (from a device emitting strong electromagnetic fields)	Move the product or problematic device further away.
	The extension card was removed while the power was still on.	The product needs to be reset by Riken Keiki. Contact Riken Keiki.

Symptom/display	Cause	Action
The product operates sluggishly.	Auto-refresh has not been disabled.	Follow the instructions provided in ' 7-3-6 Disabling auto-refresh p. 40 '.
Cannot log in.	The password is incorrect.	Check the password. Check the initial password provided in this manual. (Refer to ' 7-1-3 Accessing the system with a local connection p. 25 '.)
I forgot the password. I do not know the password.	Talk2M account password (When connected to the Internet)	Click [Forgot Password?] on the eCatcher (refer to ' 7-2-2 Creating a Talk2M account p. 27 ') login screen.

11 List of Specifications

Hardware	Ewon Flexy 205
Software	GADMS Lite
Supported gas detectors	GD-70D-EA, SC-70-ET
Number of connected gas detectors	96 Max.
Installation	DIN rail or wall mounted
Power supply indication	Power lamp lit (green)
Display items	Gas name display Gas concentration display Flow display Gas alarm display (ALM1/ALM2) Fault alarm display (Sensor/Flow/Communication) Mode display (Maintenance/Test/Inhibit)
Ethernet ports	RJ45 Ethernet 10/100 MB × 4 (WAN port × 1, LAN ports × 3)
External input	Digital input ×1 (reset signal)
Alarm contact	No-voltage contact 1a × 4 (ALM1/ALM2/Fault/Buzzer)
Heartbeat interval	Max. 10 s interval (depending on number of contacts) Repeated ON/OFF, open drain (MOSFET) 200 mA, 1.5 kV insulation
Contact capacity	30 V 2 A AC/DC
Functions	Display: Chart/Detail/Summary/Alarm History (in browser) Email transmission (Alarm/Fault/Reports)
Power supply	12 - 24 V DC ± 20 %
Power consumption	72 W Max.
Startup time	180 seconds
Expansion memory capacity	SD card (4 GB) (for saving log data)
KPI display function	Key performance indicator display (PC, smartphone, tablet, etc.)
Sampling time	Up to 10 seconds (with maximum number of detectors connected)
Certification	CE marking, cULus listed, FCC (Ewon Flexy 205)
Operating temperature range	-25 °C - +60 °C (no sudden fluctuations)
Operating humidity range	10 % - 95 % (no condensation)
External dimensions	Approx. 55 (W) × 133 (H) × 122 (D) mm

12 Terminology

Term	Definition
ALM1	Abbreviation for Alarm 1 A caution alarm
ALM2	Abbreviation for Alarm 2 A main alarm
MAINT	Abbreviation for Maintenance Refers to Maintenance mode.