

RI-215A

Operator's Manual

Part Number: 71-0045RK

Revision 0

Released: 10/3/05

Warranty

RKI Instruments, Inc., warrants gas alarm equipment sold by us to be free from defects in materials and workmanship, and performance for a period of one year from date of shipment from RKI Instruments, Inc. Any parts found defective within that period will be repaired or replaced, at our option, free of charge. This warranty does not apply to those items which by their nature are subject to deterioration or consumption in normal service, and which must be cleaned, repaired, or replaced on a routine basis. Examples of such items are:

Absorbent cartridges	Batteries
Pump diaphragms and valves	Filter elements
Fuses	

Warranty is voided by abuse including mechanical damage, alteration, rough handling, or repairs procedures not in accordance with the instruction manual. This warranty indicates the full extent of our liability, and we are not responsible for removal or replacement costs, local repair costs, transportation costs, or contingent expenses incurred without our prior approval.

THIS WARRANTY IS EXPRESSLY IN LIEU OF ANY AND ALL OTHER WARRANTIES AND REPRESENTATIONS, EXPRESSED OR IMPLIED, AND ALL OTHER OBLIGATIONS OR LIABILITIES ON THE PART OF RKI INSTRUMENTS, INC., INCLUDING BUT NOT LIMITED TO THE WARRANTY OF MERCHANTABILITY OR FITNESS FOR A PARTICULAR PURPOSE. IN NO EVENT SHALL RKI INSTRUMENTS, INC., BE LIABLE FOR INDIRECT, INCIDENTAL, OR CONSEQUENTIAL LOSS OR DAMAGE OF ANY KIND CONNECTED WITH THE USE OF ITS PRODUCTS OR FAILURE OF ITS PRODUCTS TO FUNCTION OR OPERATE PROPERLY.

This warranty covers instruments and parts sold to users only by authorized distributors, dealers, and representatives as appointed by RKI Instruments, Inc.

We do not assume indemnification for any accident or damage caused by the operation of this gas monitor and our warranty is limited to replacement of parts or our complete goods.

Table of Contents

Chapter 1: Introduction	5
Overview	5
About the RI-215A	5
Measuring Mode	5
Maintenance Mode	5
Alarm Adjust Mode	5
Specifications	6
About this Manual	6
Chapter 2: Description	7
Overview	7
External Description	7
Case	7
Cable Assembly	8
Internal Description	8
Printed Circuit Board	8
LCD	9
IR Gas Sensor	9
Fuse	9
Chapter 3: Installation	10
Overview	10
Mounting the RI-215A	10
Wiring the RI-215A	12
Notes on Wiring the RI-215A	12
Connecting the Power	13
Connecting the RI-215A to a Recorder	13
Connecting the RI-215A to a Controller	14
Connecting the RI-215A to an External Alarm Device	14
Start Up	14
Introducing Power to the RI-215A	14
Warm Up	14
Preparing to Set the Zero	15
Setting the Zero Reading	15
Chapter 4: Operation	16
Overview	16
Measuring Mode	16
Alarm Indications	16
Responding to Alarms	16
Analog Output	17
Alarm Point and Ventilation Control	17
Alarm Adjust Mode	18

Verifying the Alarm Point	18
Adjusting the Alarm Point	18
Chapter 5: Maintenance	20
Overview	20
Preventive Maintenance	20
Daily	20
Quarterly	20
Troubleshooting	20
Replacing Components	21
Replacing the Sensor	21
Replacing the Fuse	21
Calibration	22
Preparing for Calibration	22
Setting the Zero Reading	22
Setting the Response Reading	22
Returning to Normal Operation	23
Parts List	23
Appendix A: Changing the Detection Range	24

Chapter 1: Introduction

Overview

This chapter briefly describes the RI-215A. This chapter also describes the *RI-215A Operator's Manual* (this document). Table 1 at the end of this chapter lists the specifications for the RI-215A.

About the RI-215A

The RI-215A Air Quality Monitor detects the presence of CO₂ (carbon dioxide) using an infrared (IR) gas sensor. The RI-215A shows increasing levels of CO₂ on its liquid crystal display (LCD). It also displays a visual alarm should levels of CO₂ exceed the unit's full scale (e.g., 2,000 ppm). Alarm contacts on the RI-215A are also provided, which enable you to connect an external alarm to the unit.

Three ranges of gas detection are available for the RI-215A: 0 - 2,000 ppm, 0 - 5,000 ppm, and 0 - 9990 ppm. Detection ranges are set at the factory. When you ordered the RI-215A, you should have specified one of these gas detection ranges for your unit. It becomes necessary to change the detection range, See "Appendix A: Changing the Detection Range" on page 24.

The RI-215A operates in three modes: Measuring Mode, Maintenance Mode, and Alarm Adjust Mode.

Measuring Mode

Measuring Mode is the mode in which the RI-215A detects, measures, and displays CO₂ (normal operation).

Maintenance Mode

Maintenance Mode allows you to perform maintenance tasks. These tasks include:

- adjusting the zero setting
- adjusting the span setting
- changing the detection range

CAUTION: *The RI-215A is not in operate as a gas monitor when you are in Maintenance Mode.*

Alarm Adjust Mode

Alarm Adjust Mode allows you to verify and change the alarm point.

Specifications

Table 1 lists specifications for the RI-215A.

Table 1: Specifications

Power Source	24 VAC or 24 VDC
Target Gas	CO ₂ (carbon dioxide)
Sampling Method	Diffusion
Area Classification	Indoor, nonhazardous locations
Signal Output	4 to 20 mA
Accuracy	± 5% of full scale
Fuse ¹	0. 5A, 125 V (5 mm x 20 mm)

¹ A 0.5A, 250 V fuse is an acceptable replacement.

About this Manual

The *RI-215A Operator's Manual* uses the following conventions for notes, cautions, and warnings.

NOTE: Describes additional or critical information.

CAUTION: *Describes potential damage to equipment.*

WARNING: *Describes potential danger that can result in injury or death.*

Chapter 2: Description

Overview

This section describes the external and internal components of the RI-215A.

External Description

Case

The RI-215A's steel case is radio frequency (RF)-resistant. It is suitable for installation in indoor areas where general purpose equipment is in use.

The case has a front housing and a base plate, which snap together. The front housing has a LCD window, which is shown in the front view of Figure 1.

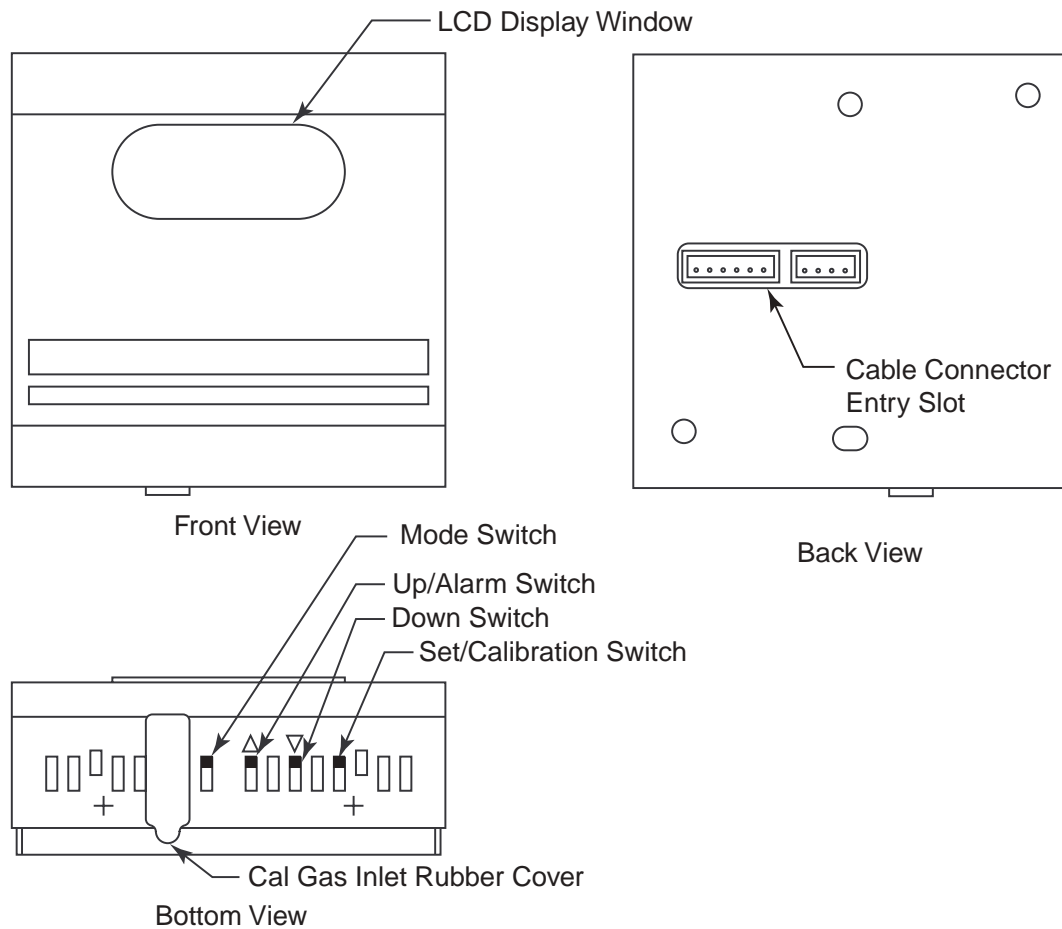

Figure 1: Component Location of the RI-215A

On the bottom of the front housing is a series of slots and a calibration port. The slots allow the target gas sample to enter the IR gas sensor in the RI-215A. The calibration port is covered with a rubber cap. The calibration port accepts $\frac{1}{4}$ -inch ID (inside diameter) flexible tubing. A series of switches are accessible to the right of the calibration port, as shown in Figure 1 on page 7. These switches include:

- Mode (M)
- Up/Alarm (Δ)
- Down (∇)
- Set/Calibration (S)

The base plate has a wire entry slot for the cable assembly. The cable assembly connects directly to the printed circuit board inside the case through the cable entry slot. The cable assembly is used to connect to an external power source. You also use it to make connections to an external alarm and to a monitoring or recording device. The base plate has two mounting holes for convenient mounting on vertical surfaces at the monitoring site.

Cable Assembly

The cable assembly connects to a six-pin receptacle on the printed circuit board through a slot on the rear of the case. It allows you to make external wiring connections to the RI-215A.

Internal Description

Printed Circuit Board

On the printed circuit board is located the IR gas sensor, LCD, and fuse. Connected to the printed circuit board is the cable assembly.

The printed circuit board converts the output of the IR gas sensor to a 4-to-20 mA signal (that is proportional to the detection range of the RI-215A). The printed circuit board also displays a digital reading on the LCD.

The printed circuit board has four switches: Mode (M), Up/Alarm (Δ), Down (∇), and Set/Calibration (S). These switches are located at the bottom of the printed circuit board beneath the gas sensor. Table 2 lists each switch and its function.

Table 2: Model RI-215A Program Switches

Switch	Function
Mode (M)	Enters Maintenance Mode
Up/Alarm (Δ)	<ul style="list-style-type: none"> • Increases the setting on the LCD • Displays the alarm point
Down (∇)	<ul style="list-style-type: none"> • Decreases the setting on the LCD
Set/Calibration (S)	<ul style="list-style-type: none"> • Prepares a setting to be changed • Enters a new setting

LCD

The LCD is mounted to the printed circuit board. The LCD shows the current gas reading of the RI-215A's target gas. The LCD also shows operational messages when the RI-215A exceeds its full scale.

IR Gas Detector

The IR detector uses infrared light and an infrared sensor to detect CO₂. A small infrared light source is located in the detector. As CO₂ enters the detector, it absorbs infrared light in a characteristic way as the concentration increases. The infrared sensor detects this change in infrared light and the unit converts this to a gas concentration.

Fuse

One extractor-type fuse protects the AC line circuitry from short circuit or overload. The fuse is rated at 0.5A, 125 V. See "Parts List" on page 23.

Chapter 3: Installation

Overview

This chapter describes how to install the RI-215A at the monitoring site. This section also includes procedures to make power and other wiring connections to the RI-215A.

Mounting the RI-215A

CAUTION: *The RI-215A is suitable for installation in indoor areas where general purpose equipment is in use.*

1. Select a mounting site that is representative of the monitoring environment. Consider the following when you select the mounting site:
 - Select a site near the sampling area in which the RI-215A is not likely to be bumped or disturbed.
 - Choose a location not subject to significant air movement, for example, near an air conditioning or heating vent.
 - Mount the RI-215A in an area not subject to large temperature and humidity changes.
 - Mount the RI-215A on the wall at least six feet from the floor to minimize the possibility of someone breathing on the unit. The exhaled CO₂ may cause an alarm.
 - Make sure there is sufficient room to make wiring connections through the back of the unit, and to remove the unit from the base plate to perform maintenance, such as replacing the fuse.
2. For wall-mounting, remove the base plate of the RI-215A.
 - Using a small screw driver, press down on the small tab on top of the Model RI-215A.
 - While pushing down on the tab, gently move the base plate away from the front housing of the RI-215A.

CAUTION: *Be very careful not to pull on the cable assembly connected to the RI-215A's internal printed circuit board when removing the base plate. Pulling on the cable assembly may damage the printed circuit board.*

- Completely separate the base plate from the front housing.

- Use two screws to secure the base plate to the wall. Figure 2 below shows the location of the screw holes in the base plate.

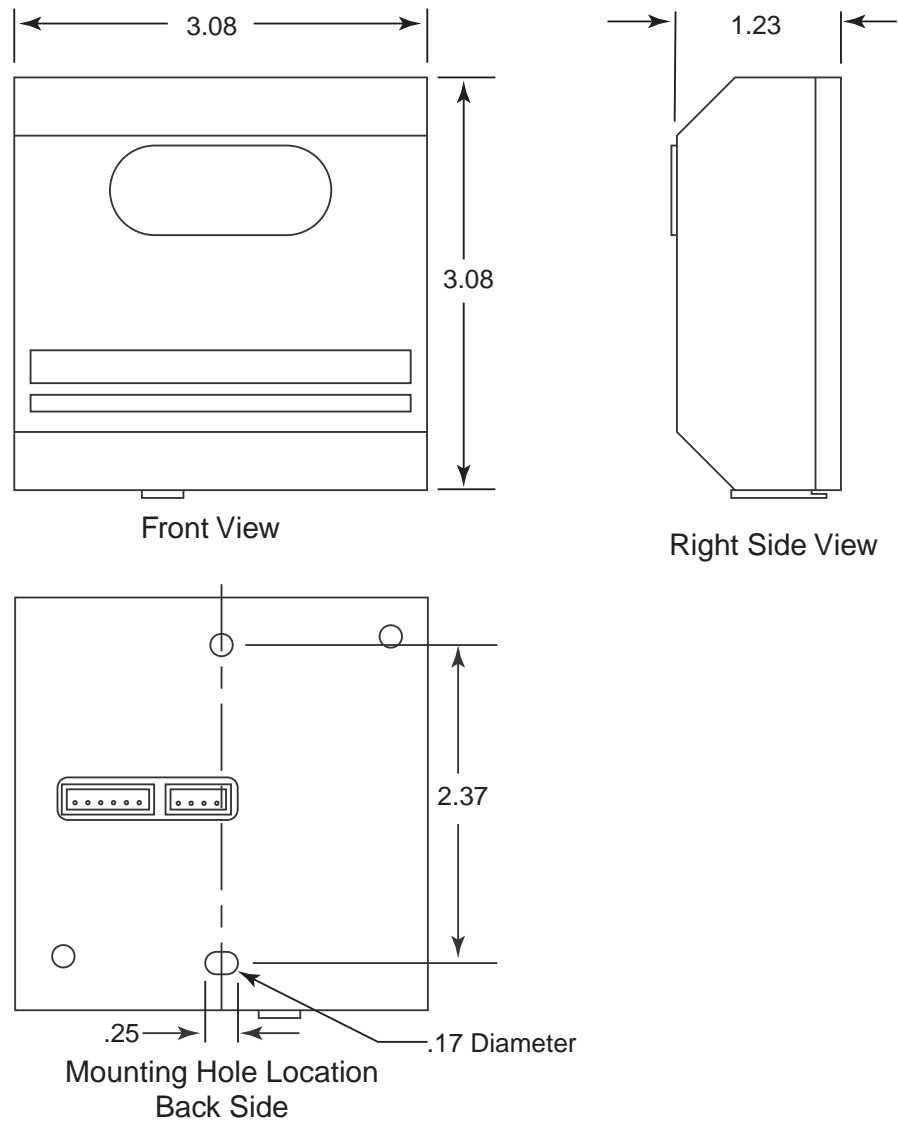

Figure 2: RI-215A Outline and Mounting Dimensions

- Reassemble the base plate and the front housing of the RI-215A in the reverse order as described in step 2 above. Line up the bottom of the base plate with the front housing, then carefully snap the base plate and front housing together.

Wiring the RI-215A

This section describes procedures to connect power to the RI-215A. This section also describes optional procedures to connect a controller or recorder and external alarm device to the RI-215A.

WARNING: *To reduce the risk of electric shock, always verify that power to the RI-215A has been turned off before making any wiring connections to the RI-215A. Make sure to operate the RI-215A from the specified power voltage of 24VAC/VDC, and follow the local electric code when making all electrical connections.*

Notes on Wiring the RI-215A

- Use a stable 24 VAC or 24 VDC power source. Do not use a noisy power source. If the power source is noisy, use a line filter to eliminate the noise.
- Use shielded cable for the output signal line in cases where noise is a potential problem.
- The alarm relay contacts in the RI-215A are rated at 0.5A, 125 VAC. Do not use these contacts to control an electrical load larger than this rating. For large load control, use the RI-215A alarm contacts to control a slave relay with an appropriate contact rating.

Figure 3 below shows the general wiring diagram of the RI-215A, and is not specific to any device to which the unit could be connected. The red wires of the cable assembly, as shown in Figure 3 below, connect to an external 24 VAC or 24 VDC power supply. The white wires serve as a relay contact and can be used to control an external alarm. The yellow and blue wires carry a 4 - 20 mA output signal. These wires can be connected to a gas monitoring controller or a recording device.

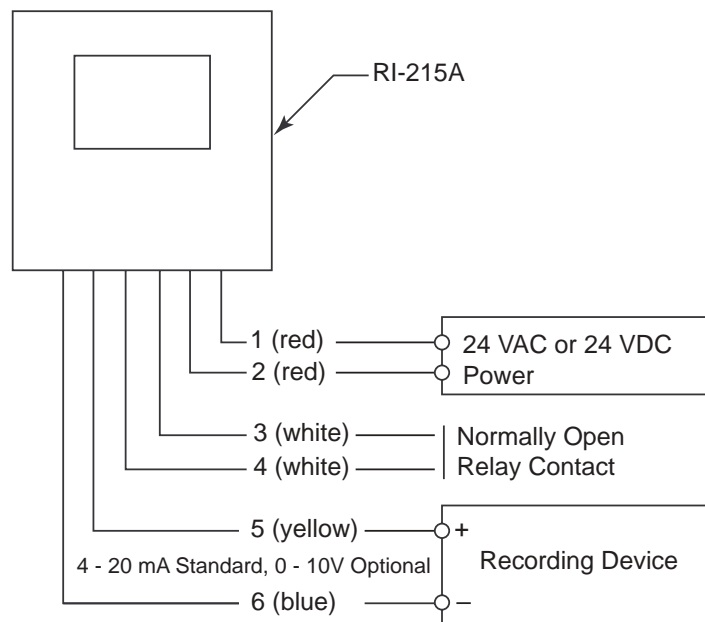

Figure 3: General Wiring Diagram of the RI-215A

Figure 4 below shows how to wire the RI-215A to a controller that accepts 3-wire, 4-20 mA transmitters.

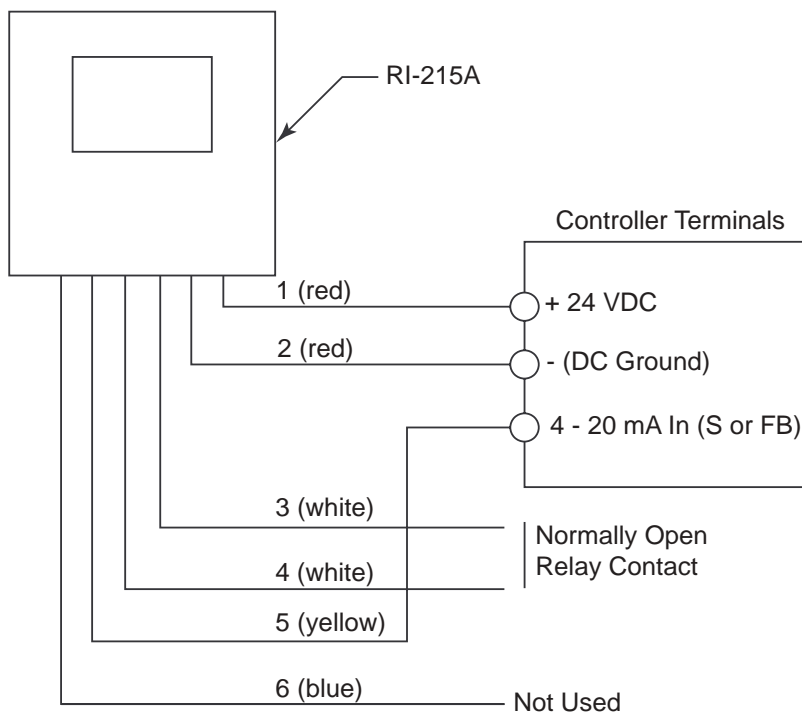

Figure 4: Wiring Diagram of the RI-215A as a 3-Wire 4-20 mA Transmitter

Connecting Power

1. Verify that power to the RI-215A has been turned OFF.
2. Connect the two red AC line cables to the 24 VAC or 24 VDC power source. Refer to the wiring diagram in Figure 3 on page 12.
3. If you do not plan to make any more wiring connections, then terminate the remaining cables appropriately to avoid an electrical short.

Connecting the RI-215A to a Recorder

Perform the following procedure to connect the RI-215A to a recorder. The output of the RI-215A is a 4-to-20 mA signal, which is proportional to the detection range.

NOTE: The standard output of the RI-215A is 4 - 20 mA. An optional output of 0 -10 V is available and must be specified at the time of your order.

1. Verify that power to the RI-215A has been turned OFF.
2. Connect the yellow (+) and blue (-) wires to the controller or recording device. Refer to the wiring diagram in Figure 3.
3. If you do not plan to make any more wiring connections, then terminate the remaining wires.

Connecting the RI-215A to a Controller

Perform the following procedure to connect the RI-215A as a 3-wire 4 - 20 mA transmitter to a controller.

1. Verify that power to the RI-215A has been turned OFF.
2. Connect one of the red wires from the RI-215A to the +24V transmitter terminal at the controller.
3. Connect the other red wire to the - (DC ground) transmitter terminal at the controller.
4. Connect the yellow wire to the S or FB transmitter terminal at the controller.

Connecting the RI-215A to an External Alarm Device

CAUTION: *The maximum current rating of the normally-open, dry contacts is 0.5 amp. If the alarm device exceeds this rating, use the alarm contacts to control a relay with an appropriate current rating.*

1. Verify that power to the RI-215A has been turned OFF.
2. Connect the white wires to the external alarm. Refer to the wiring diagram in Figure 3 on page 12.
3. If you do not connect the white wires to an alarm device, terminate these unused wires.

Start Up

This section describes procedures to start up the RI-215A and place the RI-215A into normal operation.

Introducing Power to the RI-215A

- Complete all installation procedures described earlier in this chapter.
- Verify that the wiring supplying power to the RI-215A has been connected correctly.
- Turn on or plug in the incoming power at the power source.
- Verify that the RI-215A shows a readout on its LCD as described in the next subsection.

Warm Up

After you have turned on the power to the RI-215A, the unit takes about one minute to begin operating. During this initial warm-up period, "CO₂" is shown on the unit's LCD.

After the initial warm up is completed, the gas sensor inside the RI-215A detects the presence of CO₂, and displays the concentrations of this gas on its LCD. Simultaneously, the RI-215A also outputs a 4-to-20 mA signal (0 to 10 V optional) which corresponds to the gas concentration.

CAUTION: *Allow the RI-215A to warm up for an additional 30 minutes before continuing.*

Preparing to Set the Zero

Connect the sample tubing from your calibration kit to the hose barb on the fixed flow regulator. The fixed flow regulator should be a 0.5 LPM regulator.

NOTE: Do not connect the regulator to the calibration cylinder at this time.

Setting the Zero Reading

1. Locate the function switches on the bottom of the unit.
2. Press and hold the MODE switch (M) for three seconds to enter Maintenance Mode. The display will show "1" to indicate Zero Adjustment Mode.
3. Press the SET switch (S) to enter Zero Adjustment Mode. The display will show a reading with a flashing decimal point before the first and third digits, for example ". 1.5".
4. Remove the rubber cap covering the calibration gas inlet port at the bottom of the unit.
5. Insert the calibration tubing into the gas inlet opening at the bottom of the RI-215A and push the tubing over the calibration fitting.
6. Screw a 100% nitrogen calibration cylinder (a CO₂-free source) into the regulator.
7. Allow the gas to flow for one minute or until the gas reading stabilizes.
8. Press the SET switch (S) and the unit will adjust the reading to zero. Be careful not to breath onto the RI-215A since the CO₂ in your breath may affect the reading.
9. Press the SET switch (S) and the display will again show a "1".
10. Unscrew the regulator from the nitrogen cylinder.
11. To return to normal operation, press the MODE switch for three seconds to exit Maintenance Mode.

Chapter 4: Operation

Overview

This chapter describes Measuring Mode and Alarm Adjust Mode. Under Measuring Mode, alarm indications are discussed along with responding to alarms, analog output, and alarm point and ventilation control. Under Alarm Adjust Mode, verifying the alarm point and adjusting the alarm point are described.

Measuring Mode

When the RI-215A is in Measuring Mode (normal operation), it displays the current concentration of CO₂ on its LCD and outputs a 4 - 20 mA signal that corresponds to the CO₂ concentration. The typical background CO₂ level is 200 - 400 ppm.

Alarm Indications

If the CO₂ concentration rises above the alarm point, the relay contact will actuate. If the gas concentration exceeds the full scale, the LCD shows:



Responding to Alarms

1. Follow your established procedure for handling high levels of CO₂ gas.
2. When the display reading falls below the alarm point, the alarm circuit automatically resets itself.

Analog Output

The RI-215A's analog output, available via the yellow and blue wires of the cable assembly (refer to Figure 3 on page 12), is proportional to the concentration of CO₂ for all gas ranges (e.g., 0 - 2,000 ppm, 0 - 5,000 ppm, and 0 - 9990 ppm), as shown in Figure 4.

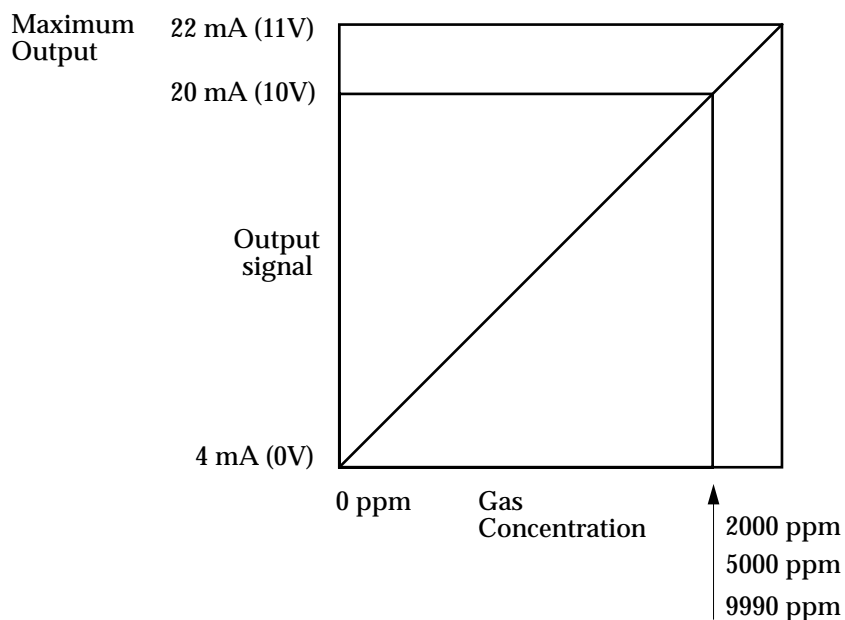

Figure 5: Model RI-215A's CO₂ Level to Output Signal

Should the concentration of CO₂ present in the monitoring environment be above full scale (i.e., it exceeds the upper gas range of your unit), the highest output will be 22 mA, or 11 V, depending on the output, current, or voltage, selected at the factory. The LCD of the RI-215A will show a series of brackets (upside down "Us") between 20 mA (10 V) and 22 mA (11V). The standard output setting for the RI-215A is 4- 20 mA.

Alarm Point and Ventilation Control

The RI-215A's alarm relay has a built-in hysteresis of 50 ppm (refer to Figure 6 on page 18). After the alarm point has been reached (e.g., 1000 ppm), the alarm relay will activate. As the CO₂ concentration begins to fall, the alarm relay will deactivate 50 ppm below the activation point (e.g., 950 ppm). The 50 ppm hysteresis keeps the alarm contacts from "chattering" should the CO₂ concentration hover around the alarm point.

So if the alarm relay contacts are wired to turn on a ventilation system when the concentration of CO₂ reaches the alarm point (e.g., 1000 ppm), the ventilation system will remain on until the concentration of CO₂ falls to 50 ppm below the alarm point (e.g., 950).

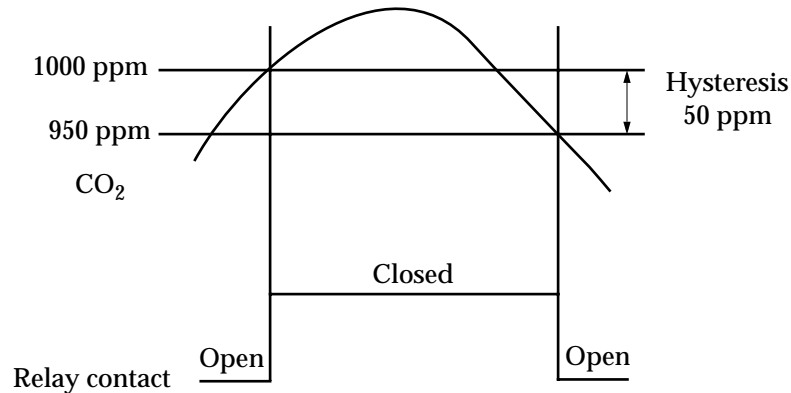

Figure 6: Model RI-215A's Built-in Hysteresis of 50 ppm

Alarm Adjust Mode

Use the Up (Δ) switch to enter Alarm Adjust Mode.

Verifying the Alarm Point

Three ranges of gas detection are available for the RI-215A: 0 - 2,000 ppm, 0 - 5,000 ppm, and 0 - 9990 ppm. Detection ranges are set at the factory. When you ordered the RI-215A, you should have specified one of these gas detection ranges for your unit.

The alarm point of the RI-215A is also set at the factory (e.g., 1000 ppm). To display the current alarm point from the normal LCD, do the following:

1. Press and hold the Up (Δ) switch. The alarm point appears (e.g., 10:00) on the LCD (alarm verification screen). In this example, 10:00 indicates an alarm point of 1000 ppm. Note that the colon (:) will be flashing.
2. Release the Up (Δ) switch to return to the normal LCD. Do not hold the (Δ) switch for more than three seconds or the unit will display the Alarm Adjust screen.

Further note that the RI-215A's alarm relay has a built-in hysteresis (lag) of 50 ppm. After the alarm point has been reached (e.g., 1000 ppm), the alarm relay will activate. As the CO₂ concentration begins to fall, the alarm relay will deactivate 50 ppm below the activation point (e.g., 950 ppm). The 50 ppm hysteresis keeps the alarm contacts from "chattering" should the CO₂ concentration hover around the alarm point.

Adjusting the Alarm Point

To adjust the alarm point, do the following:

1. Press and hold the Up (Δ) switch for three seconds to display the Alarm Adjust screen. The LCD will flash the alarm point setting and the colon (:) alternately.
2. Use the Up (Δ) and Down (∇) switches to adjust the alarm point to the setting you want (e.g., 11:00 = 1100 ppm, 12:00 = 1200ppm, 12:30 = 1230ppm, 13:00 = 1300 ppm, etc.)
3. Press the SET switch to save the new alarm point. The unit returns to normal operation and the LCD displays the current gas reading.

Chapter 5: Maintenance

Overview

This chapter describes maintenance and troubleshooting procedures for the RI-215A. It includes instructions for the replacement of the RI-215A's gas sensor and fuse and calibration procedures. A spare parts list is located at the end of this chapter.

Preventive Maintenance

This section describes a preventive maintenance schedule.

Daily

Verify a display reading for CO₂ in ppm. Investigate significant changes in the reading. Typical background levels of CO₂ are 200 to 400 ppm, depending on location.

Quarterly

Calibrate the unit. See See "Calibration" on page 22.

Troubleshooting

The troubleshooting table describes error messages, symptoms, probable causes, and recommended action for problems you may encounter with the RI-215A.

Table 3: Troubleshooting the RI-215A

Symptoms	Probable Causes	Recommended Action
<ul style="list-style-type: none">The LCD does not show a gas reading or is blank.	<ul style="list-style-type: none">Power may have been terminated to the unit.The unit may have been incorrectly connected to a power source.The wrong power source is being used to run the unit.The fuse may have blown.The unit may be in Maintenance Mode.	<ol style="list-style-type: none">Verify that the power source has been turned on and is working.If a circuit breaker has been used in the installation of the RI-215A, make sure that the circuit breaker has not been activated.Verify that the wiring to the power source has been connected correctly.Make sure you have used the correct power source: 24 VAC or 24 VDC.Open the unit and check the fuse. Replace the fuse if required. The RI-215A takes the following replacement fuse: 0.5A, 125 VAC (5.2 mm x 20 mm).The unit may be in Maintenance Mode. Press the MODE switch for three seconds, or until a gas reading appears.If difficulties continue, contact RKI.

Table 3: Troubleshooting the RI-215A

Symptoms	Probable Causes	Recommended Action
<ul style="list-style-type: none">The LCD shows abnormally high or low CO₂ readings but other gas detection instruments show a normal level of CO₂.	<ul style="list-style-type: none">The RI-215A may need to be recalibrated.	<ol style="list-style-type: none">Recalibrate the unit.
<ul style="list-style-type: none">Unable to zero or span reading during calibration.	<ul style="list-style-type: none">The calibration cylinder is low, outdated, or defective.	<ol style="list-style-type: none">Verify that the calibration cylinder contains an adequate supply of sample.If difficulties continue, contact RKI.

Replacing Components

The section includes procedures to replace the sensor and fuse.

Replacing the Detector

The CO₂ gas detector inside the RI-215A is a factory replacement part. Should you determine that the RI-215A's gas detector is no longer working or is working improperly, you will need to ship the RI-215A to RKI Instruments, Inc. to have the detector replaced.

Replacing the Fuse

- Turn off the power to the RI-215A.
- Remove the base plate of the RI-215A.
 - Using a small screw driver, press down on the small tab on top of the Model RI-215A.
 - While pushing down on the tab, gently move the base plate away from the front housing of the RI-215A.

CAUTION: *Be very careful not to pull on the cable assembly connected to the RI-215A's internal printed circuit board when removing the base plate. Pulling on the cable assembly may damage the printed circuit board.*

- Completely separate the base plate from the front housing.
- Find the fuse on the left side of the printed circuit board. Carefully remove the fuse from the bracketing holding it on the printed circuit board.
 - Insert a new fuse in the brackets. The replacement fuse must be 0.5A, 125 V or 250 V (5 mm x 20 mm).
 - Reassemble the base plate and the front housing of the RI-215A in the reverse order as described in step 2 above. Line up the bottom of the base plate with the front housing, then carefully snap the base plate and front housing together.
 - Turn the power back on to the RI-215A.

Calibration

This section describes how to calibrate the RI-215A. It includes procedures to prepare for calibration, set the zero reading, set the response (span) reading, and return to normal operation.

WARNING: *The RI-215A is not an active gas monitoring device during the calibration procedure.*

Preparing for Calibration

Turn on the power to the RI-215A, and let the unit warm up for at least 30 minutes. Connect the sample tubing from your calibration kit to the hose barb on the fixed flow regulator. The fixed flow regulator should be a 0.5 LPM (liters per minute) regulator.

NOTE: Do not screw the regulator onto the calibration cylinder at this time.

Setting the Zero Reading

1. Locate the function switches on the bottom of the unit.
2. Press and hold the MODE switch (M) for three seconds to enter Maintenance Mode. The display will show “1” to indicate Zero Adjustment Mode.
3. Press the SET switch (S) to enter Zero Adjustment Mode. The display will show a reading with a flashing decimal point before the first and third digits, for example “. 1.5”.
4. Remove the rubber cap covering the calibration gas inlet port at the bottom of the unit.
5. Insert the calibration tubing into the gas inlet opening at the bottom of the RI-215A and push the tubing over the calibration fitting.
6. Screw a 100% nitrogen calibration cylinder (a CO₂-free source) into the regulator.
7. Allow the gas to flow for one minute or until the gas reading stabilizes.
8. Press the SET switch (S) and the unit will adjust the reading to zero. Be careful not to breath onto the RI-215A since the CO₂ in your breath may affect the reading.
9. Press the SET switch (S) and the display will again show a “1”.
10. Unscrew the regulator from the nitrogen cylinder.
11. To proceed with setting the span, press the Up (Δ) switch to display “2” which indicates Span Adjustment Mode and continue with the next section, Setting the Response Reading.
12. To return to normal operation, skip to Returning to Normal Operation below.

Setting the Response Reading

1. With “2” showing in the display, press the SET switch (S) to enter Span Adjustment Mode. The display will show the current gas reading with a flashing decimal point before the second and third digits, for example “.6.50”.
2. Press the SET switch (S) again and the reading will start to flash.

3. If not already in, insert the calibration tubing into the gas inlet opening at the bottom of the RI-215A and push the tubing over the calibration fitting.
4. Screw the calibration cylinder into the regulator.
5. Allow the calibration gas to flow for one minute or until the gas reading stabilizes.
6. If the gas reading does not match the gas concentration, use the Up (Δ) and Down (∇) switches to adjust the reading to the gas concentration.
7. Press the SET switch (S) to set the reading and exit Span Adjustment Mode. The display will show a "2".
8. Unscrew the regulator from the calibration cylinder.
9. Remove the calibration tubing from the calibration fitting on the RI-215A.
10. Allow time for the gas reading on the RI-215A display to return to a normal level.

Returning to Normal Operation

1. Press the MODE switch for three seconds to exit the Maintenance Mode and return to normal operation.

NOTE: If you do not allow the gas reading to return to normal, then unwanted alarms may occur.

2. Store the components of the calibration kit in a safe and convenient place.

Parts List

Table 4 lists replacement parts and accessories for the RI-215A carbon dioxide transmitter.

Table 4: Parts List

Part Number	Description
06-1252RK	Sample tubing (1/4 x 1/8 in.; specify length when ordering)
43-4139RK	Replacement fuse, 0.5A, 250 V, 5 mm x 20 mm
81-0070RK-01	Calibration cylinder (2,000 ppm carbon dioxide; 34 liter)
81-0071RK-01	Calibration cylinder (5,000 ppm carbon dioxide; 34 liter)
81-0078RK-01	100% nitrogen calibration cylinder (34 liter)
81-1003RK	Regulator, 0.5 liter/minute; continuous flow (for 17 and 34 liter calibration cylinders)

Appendix A: Changing the Detection Range

The RI-215A can be setup for one of three detection ranges: 0 - 2,000 ppm; 0 - 5,000 ppm; 0 - 9990- ppm. When the RI-215A is ordered, the detection range must be specified. If it is necessary to change the detection range in the field, this can be done in Maintenance Mode.

WARNING: The RI-215A is not an active gas monitoring device during the full scale adjustment procedure.

Perform the following to change the detection range.

1. With the RI-215A on and in Measuring Mode, locate the function switches on the bottom of the unit.
2. Press and hold the MODE switch (M) for 3 seconds to enter Maintenance Mode. The display will show "1" to indicate Zero Adjustment Mode.
3. Press the Up (Δ) switch until the display shows "3" to indicate Full Scale Adjustment Mode.
4. Press the SET switch (S) to enter Full Scale Adjustment Mode. The display will show a full scale value with a flashing decimal point after the first digit, for example "2.000".
5. Use the Up (Δ) and Down (∇) switches to scroll through the full scale value choices until the desired full scale value is displayed.
6. Press the SET switch (S) to accept the displayed full scale value. The display will again show a "3".
7. Press the MODE switch for 3 seconds to exit Maintenance Mode and return to Measuring Mode.
8. Calibrate the RI-215A as described in "Calibration" on page 22.

WARNING: The RI-215 must be calibrated after the detection range is changed. The RI-215A readings will not be accurate unless a calibration is performed.
